



# How alexithymia shapes functional networks: Insights from a general population study

Elischa Krause<sup>1</sup> , Johanna Klinger-König<sup>1</sup> , Katharina S. Goerlich<sup>2,3</sup> ,  
Stefan Frenzel<sup>1</sup> , Robin Bülow<sup>4</sup> , Mark Oliver Wielpütz<sup>4</sup> , Henry Völzke<sup>5,6,7</sup>   
and Hans J. Grabe<sup>1,8</sup>

## Research Article

**Cite this article:** Krause E, Klinger-König J, Goerlich KS, Frenzel S, Bülow R, Wielpütz MO, Völzke H, Grabe HJ (2026). How alexithymia shapes functional networks: Insights from a general population study. *European Psychiatry*, 69(1), e45, 1–15  
<https://doi.org/10.1192/j.eurpsy.2026.10177>

Received: 30 October 2025

Revised: 23 January 2026

Accepted: 30 January 2026

### Keywords:

alexithymia; emotional processing; functional connectivity; rsfMRI; TAS-20

### Corresponding author:

Elischa Krause;

Email: [elischa.krause@uni-greifswald.de](mailto:elischa.krause@uni-greifswald.de)

Elischa Krause and Johanna Klinger-König share the first authorship as they contributed equally to this work.

<sup>1</sup>Department of Psychiatry and Psychotherapy, University Medicine Greifswald, Greifswald, Germany; <sup>2</sup>Center for Clinical Neuroscience and Cognition, University Medical Center Groningen, Groningen, the Netherlands; <sup>3</sup>Department of Clinical and Developmental Neuropsychology, Faculty of Behavioural and Social Sciences, University of Groningen, Groningen, the Netherlands; <sup>4</sup>Department of Diagnostic Radiology and Neuroradiology, University Medicine Greifswald, Greifswald, Germany; <sup>5</sup>Institute for Community Medicine, University Medicine Greifswald, Greifswald, Germany; <sup>6</sup>German Centre for Cardiovascular Research (DZHK), Partner Site Greifswald, Greifswald, Germany; <sup>7</sup>German Center for Diabetes Research (DZD), Site Greifswald, Greifswald, Germany and <sup>8</sup>German Center for Neurodegenerative Diseases (DZNE), Site Rostock/Greifswald, Greifswald, Germany

### Abstract

**Background.** Alexithymia is a multifaceted, transdiagnostic trait characterized by challenges in emotion processing. Affecting up to 10% in the general population, it represents a risk factor for various mental and physical health conditions. Recent neuroimaging studies have elucidated the neural substrates of alexithymia, providing initial insight into altered functional connectivity within key emotional, attentional, and interoceptive networks, potentially impairing emotion processing and everyday functioning. However, no large-scale study has yet confirmed these network alterations.

**Methods.** Resting-state functional magnetic resonance imaging from 575 individuals (ages 29–60, 334 women) in the population-based SHIP-TREND cohort, using regions of interest covering major functional networks across the whole brain, was paired with the 20-item Toronto Alexithymia Scale (TAS-20) to investigate the signature of alexithymia. The analysis accounted for technical variables, sociodemographic factors, lifestyle, and current depressive symptoms.

**Results.** Higher TAS-20 scores were associated with altered functional connectivity within the frontoparietal network and between the dorsal attention and salience networks. Specifically, the subscale “difficulties identifying feelings” was associated with functional alterations between and within attentional, salience, and sensorimotor networks, indicating a divergent pattern within the salience network.

**Conclusions.** These findings underscore the widespread impact of alexithymia on brain networks involved in emotional attention, interoception, and somatosensory processing. Controlling for lifestyle factors, current depressive symptoms, and other health indicators supports the specificity of these patterns. This supports the view of alexithymia as a personality trait that affects large-scale network functioning, potentially hampering emotional regulation and self-awareness processes, contributing to mental and physical health risks.

## Introduction

Alexithymia is a multifaceted, dimensional trait characterized by challenges in processing and regulating emotions [1–3]. Originating in psychosomatic medicine, it is now recognized as a transdiagnostic trait associated with a wide range of mental and physical health conditions, especially including depression, anxiety disorders, autism spectrum disorder (ASD), post-traumatic stress disorder, cardiovascular diseases, and all-cause mortality [1, 4–14]. It represents a negative prognostic factor for psychotherapeutic treatments and affects about 10% of the general population, with substantially higher prevalence in clinical populations, including ASD (up to 49.9%) and depression (31.1%) [11, 15–22].

Theoretical and evidence-based models have been proposed to capture the facets of alexithymia. Despite differences in scope, they commonly emphasize difficulty identifying feelings (DIF), difficulty describing feelings (DDF), and externally oriented thinking (EOT) [1–3], often assessed with the Toronto-Alexithymia-Scale (TAS-20) [23–25]. The proposed fourth dimension of the Toronto Alexithymia Model, difficulty fantasizing [26], and the Amsterdam Model’s proposed dimension, difficulty emotionalizing [27], are less consistently addressed. Moreover, the Amsterdam Model extends alexithymic deficits across cognitive and affective dimensions [3, 27], whereas the Attention-Appraisal Model incorporates the valence dimension and a mechanistic perspective [2, 28].

Elevated levels of alexithymia and the three core dimensions affect emotional perception, differentiation, and expression, ranging from reduced interoceptive and emotional awareness to misinterpreted body signals (e.g., anger interpreted as nausea or physical fatigue) [29–32], which

© The Author(s), 2026. Published by Cambridge University Press on behalf of European Psychiatric Association. This is an Open Access article, distributed under the terms of the Creative Commons Attribution-NonCommercial-NoDerivatives licence (<http://creativecommons.org/licenses/by-nc-nd/4.0>), which permits non-commercial re-use, distribution, and reproduction in any medium, provided that no alterations are made and the original article is properly cited. The written permission of Cambridge University Press or the rights holder(s) must be obtained prior to any commercial use and/or adaptation of the article.



can result in maladaptive responses to physiological and emotional needs. Additionally, alexithymia can interfere with social functioning by impairing the identification of internal emotional states and external social cues (e.g., facial reactions, tone of voice), hampering socially appropriate reactions, and contributing to relationship difficulties (e.g., through reduced empathy) [33, 34]. Moreover, high alexithymia is associated with maladaptive strategies such as suppression and avoidance of emotions, which impair negative affect regulation, reduce stress resilience, and exacerbate psychological distress [35–37]. Over time, alexithymia may adversely affect the autonomic nervous system (ANS), as it is associated with autonomic dysregulation, hypothalamic–pituitary–adrenal axis alterations, and hormonal disturbances [38–40]. Together with poorer health behaviors, like reduced medical help-seeking, these factors may exacerbate mental and physical health problems, particularly affective disorders [5–14, 41–51]. Consistently, alexithymia is highly prevalent in depressive disorders, potentially due to its detrimental impact on emotion regulation [37, 52].

Neuroimaging started to elucidate the neuronal circuits underlying these alterations in alexithymia, identifying the anterior cingulate cortex (ACC), the insula, the amygdala, and prefrontal regions – key nodes of emotional awareness and interoception [53–59]. However, ongoing debates over the dimensions of alexithymia and the limited number of functional network studies leave the neurobiological mechanisms underresearched. Resting-state fMRI (rsfMRI) offers a promising approach to investigating stable, trait-level functional network alterations in alexithymia. Thus, functional connectivity (FC) within the default mode network (DMN) – essential for self-referential processing and emotional awareness – was found to be lower in individuals with alexithymia [60]. In combination with higher DMN coupling to sensory and emotion-regulatory regions, including sensorimotor, occipital, and frontal cortices, this may reflect a tonic shift from emotional awareness to exteroceptive or action-oriented processing [60]. Accordingly, other rsfMRI-studies reported altered amygdala-frontal connectivity, including the dorsolateral prefrontal cortex, ACC, precuneus, and precentral gyrus [61–63]. Additionally, lower insula-ventromedial prefrontal cortex connectivity has been shown to mediate the link between alexithymia and tobacco craving [64], suggesting reduced emotional and interoceptive awareness. However, these rsfMRI-studies relied on small, subgroup-specific samples (mostly  $N < 85$ ; one with  $N = 297$ ) and primarily used predefined regions of interest (ROI), limiting generalizability. To the best of our knowledge, no prior study has examined the impact of alexithymia on functional networks in the general population. Therefore, we investigated this in a population-based sample, hypothesizing that alexithymia – rather than frequently co-occurring depressive symptoms [52] – is associated with functional alterations specifically in the DMN, salience network (SN), and networks involved in cognitive control, attention, and sensory processing (frontoparietal network (FPN), dorsal attention network (DAN), sensorimotor network (SMN)). Previous studies have only studied alexithymia-related FC alterations in a subset of these networks [60–64]. However, large-scale networks are simultaneously active and measurable at rest, contributing to intrinsic brain activity and body regulation [65–67]. Therefore, we extended our analyses to all major whole-brain networks (cerebellar, language, and visual), broadening current knowledge.

## Methods

### Study population

Using a cross-sectional design, we analyzed data from the population-based SHIP-TREND cohort in north-eastern Germany. Participants

were randomly selected from local registries and are representative of the regional population [68]. At baseline (SHIP-TREND-0: 2008–2012;  $N = 4,420$ ; age  $M[SD] = 51.96[15.5]$ ; 2,275 females [51.5%]), the TAS-20 [23–25] was completed by 4,195 participants (94.9%). Of these, 2,507 participated in the first follow-up (SHIP-TREND-1: 2016–2019; age  $M[SD] = 57.09[13.89]$ ; 1,293 females [51.6%]), including 1,403 participants who underwent MRI scanning, including rsfMRI (age  $M[SD] = 56.18[13.05]$ ; 721 females [51.5%]) [69]. See [Supplementary Figure S1](#) for sex-stratified age distributions. We used SHIP-TREND-1 data and included only baseline TAS-20 scores, as TAS-20 was not assessed in SHIP-TREND-1.

Assessments were performed by trained personnel in accordance with the Declaration of Helsinki, with written informed consent from all participants and approval granted by the review board of the University of Greifswald, Germany.

### Data assessment

Sociodemographic, lifestyle, and medical data were collected via standardized computer-assisted interviews, followed by physical examinations including anthropometry. Socioeconomic factors included educational level (highest school and vocational training qualifications; levels: 1–8) [70, 71], and partnership status (yes/no). Lifestyle factors encompassed smoking status (never, former, current), regular physical activity  $\geq 1$  h/week (yes/no), and average alcohol consumption (g/d) during the last 30 days. Current depressive symptoms were assessed using the PHQ-9 questionnaire [72, 73] (see [Supplement](#)).

### Assessment of alexithymia

Alexithymia was assessed using the validated German version of the TAS-20 [23–25]. Each item is rated on a 5-point scale (1 = “never applies”; 5 = “applies always”), measuring one of three factors: *Difficulties Identifying Feelings*, *Difficulties Describing Feelings*, and *Externally Oriented Thinking*. Subscale scores yield a total score (range 20–100), with higher values indicating greater alexithymia. In the analysis sample, internal consistency was within previously reported ranges [74] (TAS-20 total:  $\alpha = 0.80$ ; DIF:  $\alpha = 0.83$ ; DDF:  $\alpha = 0.70$ ; EOT:  $\alpha = 0.51$ ).

The construct of alexithymia has demonstrated high relative stability [75, 76]. The TAS-20 total score showed only minor mean-level changes ( $-0.05$ ) over 11 years, along a high test–retest correlation ( $r = 0.70$ ) [77]. Consistently, alexithymia has been reported to vary only slightly over the lifespan [78–80], supporting the understanding of alexithymia as a stable, long-term personality trait [75, 81].

### Acquisition of MRI-data

Following the standard SHIP-TREND-1 protocol [69, 82], participants without contraindications underwent whole-body MRI on a 1.5 Tesla scanner (Magnetom Avanto, Siemens Healthcare, Erlangen, Germany) operated by trained technicians.

One structural T1-weighted and 200 functional brain images (repetition time (TR) = 2,860 ms, duration = 9:32 min) were acquired approximately 30–45 minutes after scan onset (see [Supplement](#) for details). During functional imaging, participants fixated on a cross with eyes open.

### Data preparation of MRI data

MRI data were preprocessed using fMRIPrep (24.1.1) [83]. Structural and functional images were coregistered, motion-corrected,

and normalized to MNI152Nlin2009cAsym space. Five nuisance regressors were derived from white matter and cerebrospinal fluid using CompCor. Functional images were subsequently coregistered to MNI152-space, spatially smoothed (8 mm), and denoised using the CONN toolbox (v22.v2407) [84, 85], including regression of CompCor components (10), motion parameters and derivatives (12), outlier scans, resting-state task effects, and linear trends. BOLD timeseries were band-pass filtered at 0.01–0.1 Hz.

FC strength was calculated by extracting the BOLD-timeseries from 32 predefined network ROIs from the CONN toolbox, derived from an independent component analysis (ICA) decomposition of 497 subjects of the Human Connectome Project (Supplementary Figure S2 and Table 1) [86]. For the planned post-hoc analysis of

**Table 1.** Network ROIs

Network	Region	Hemisphere	MNI coordinates (x, y, z)	
Cerebellar	Anterior	–	(0, –63, –30)	
	Posterior	–	(0, –79, –32)	
Frontoparietal	Lateral PFC	L	(–43, 33, 28)	
	PPC	L	(–46, –58, 49)	
	Lateral PFC	R	(41, 38, 30)	
	PPC	R	(52, –52, 45)	
Default mode	Medial PFC	–	(1, 55, –3)	
	Lateral Pole	L	(–39, –77, 33)	
	Lateral Pole	R	(47, –67, 29)	
Sensorimotor	PCC	–	(1, –61, 38)	
	Lateral	L	(–55, –12, 29)	
	Lateral	R	(56, –10, 29)	
Dorsal attention	Superior	–	(0, –31, 67)	
	FEF	L	(–27, –9, 64)	
	FEF	R	(30, –6, 64)	
	IPS	L	(–39, –43, 52)	
Language	IPS	R	(39, –42, 54)	
	IFG	L	(–51, 26, 2)	
	IFG	R	(54, 28, 1)	
	Posterior STG	L	(–57, –47, 15)	
Salience	Posterior STG	R	(59, –42, 13)	
	ACC	–	(0, 22, 35)	
	Anteriore Insula	L	(–44, 13, 1)	
	Anteriore Insula	R	(47, 14, 0)	
	Rostral PFC	L	(–32, 45, 27)	
	Rostral PFC	R	(32, 46, 27)	
	SMG	L	(–60, –39, 31)	
	SMG	R	(62, –35, 32)	
	Visual	Medial	–	(2, –79, 12)
		Occipital	–	(0, –93, –4)
Lateral		L	(–37, –79, 10)	
Lateral		R	(38, –72, 13)	

Notes: ACC, anterior cingulate cortex; FEF, frontal eye field; IPS, intraparietal sulcus; L, left; MNI, brain coordinate system developed at the Montreal Neurological Institute; PFC, prefrontal cortex; PPC, posterior parietal cortex; R, right; SMG, supramarginal gyrus; STG, superior temporal gyrus.

the DMN, a separate ICA identified four positively correlated DMN regions ( $z$ -threshold = 2.5): MPFC, PCC, and left and right lateral poles (LP) (Supplementary Figure S3). Spherical ROIs (5 mm radius) were defined at the peak coordinates of these clusters.

Then, a weighted general linear model was applied to each ROI pair to estimate their association while adjusting for confounding noise sources. Resulting bivariate correlation coefficients were Fisher  $z$ -transformed for subsequent analyses [84] (see Supplement for details).

### Analysis sample

The analysis sample was selected using QC-thresholds (Figure 1). Mean framewise movement had to be  $\leq 0.34$  mm ( $1.5 \times$  interquartile range (IQR)), with maximal displacement  $< 10$  mm. Standardized BOLD signal variation was required within  $1.5 \times$  IQR (0.14–0.26), degrees of freedom after denoising  $\geq 24$ , and  $\geq 125$  valid scans ( $\geq 62.5\%$ ,  $\sim 6$  min). Participants with stroke, MRI abnormalities, or imaging artifacts ( $n = 48$ ) were excluded. Since adherence and wakefulness during rsfMRI-acquisition were not assessed, and previous findings demonstrated that anterior–posterior DMN connectivity decouples during sleep [87], participants with low MPFC–PCC connectivity ( $z < 0.1$ ) were excluded as potentially asleep ( $n = 160$ ). The TAS-20 total score did neither correlate with MPFC–PCC coupling in the full SHIP-TREND-1 MRI sample ( $r = -.008$ ,  $p = .79$ ) nor in the analyzed sample ( $r = -.058$ ,  $p = .17$ ).

Given that age-related neurobiological and neurovascular changes may affect BOLD signals and statistical analyses in older participants [88–90], that resting-state networks change with advancing age [91–96], and that no direct measure of impaired BOLD responsiveness was available, we performed sensitivity analyses to assess potential age-related effects. Analyses of the TAS-20 total score, including both sets of covariates, were conducted using age cut-offs ranging from 55 to 75 years, showing diminishing effects when participants older than 60 years were included (Supplementary Figures S4–S5). Accordingly, a cut-off of  $> 60$  years was chosen to optimize data quality and sample size, consistent with reports identifying this age as a turning-point for declining vascular health and autonomic function [97].

Alexithymia as a trait demonstrated relative high stability across the lifespan [75, 76, 78–80]. Because no alexithymia measure was available in SHIP-TREND-1, TAS-20 scores from SHIP-TREND-0 were used, assuming relative stability of alexithymia across the time interval to MRI acquisition, while acknowledging this as a limitation.

### Statistical analysis

ROI-to-ROI analyses examined the associations between TAS-20 scores (total, DIF, DDF, EOT) and FC across eight large-scale networks: DMN, DAN, FPN, SN, SMM, Visual, Cerebellar (CN), and Language. They are assumed to contribute to intrinsic brain activity and, therefore, may be altered in alexithymia [60–67]. Post-hoc analyses were conducted on four ICA-derived DMN ROIs to increase sensitivity, as potential alexithymia-related alterations may be obscured by the anterior–posterior DMN coupling thresholds applied for quality control.

Connection-level effects between all ROI pairs were tested using multivariate random-effects analyses. Statistical inference was made at the predefined cluster level using parametric statistics within and between network pairs [98]. Results were thresholded at  $p < .05$  (connection-level) and FDR-corrected at  $p < .05$  (cluster-level) [99].

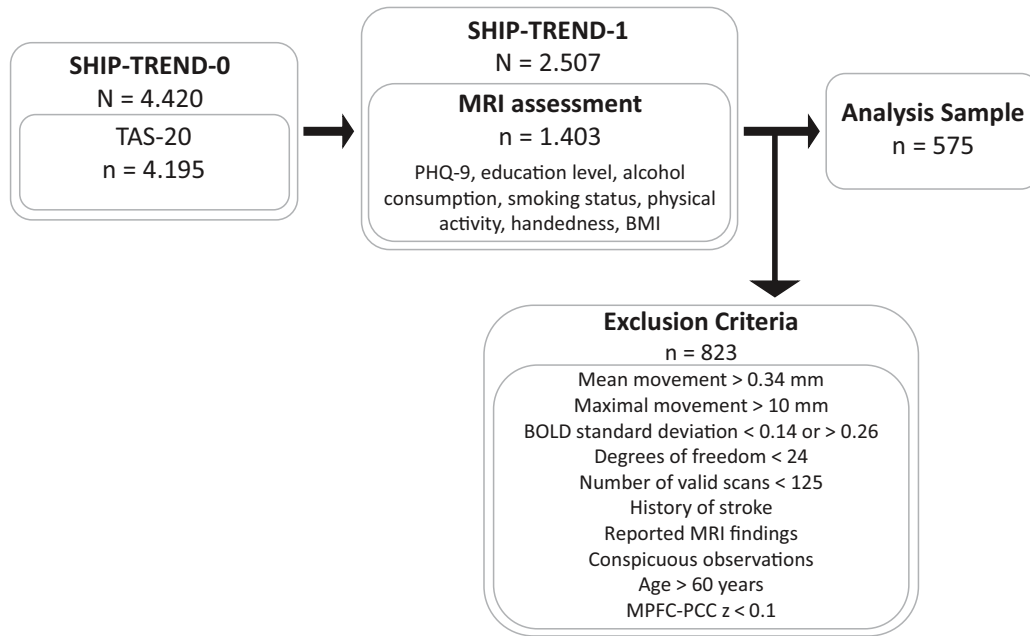

**Figure 1.** Flowchart of the analysis sample. Notes: BOLD, blood oxygen level–dependent signal; MPFC-PCC, functional connectivity between the medial prefrontal cortex and the posterior cingulate cortex; MRI, magnetic resonance imaging; PHQ-9, Patient Health Questionnaire–9; TAS-20, Toronto Alexithymia Scale; z, Fisher’s z-transformed correlation coefficient.

All analyses used a base model including age (linear and quadratic), sex, handedness, and coil configuration to control for signal variability. The fully adjusted model additionally included smoking status, PHQ-9 depression score, educational level, partnership status, physical activity, average alcohol consumption, and BMI to account for sociodemographic, clinical, and technical confounders [50, 51, 70, 71, 100–103], aiming to show that observed FC patterns are specifically linked to alexithymia.

TAS-20 and PHQ-9 scores were log-transformed to reduce skewness.

## Results

### Characteristics of the sample

The analysis sample comprised 575 participants (Table 2 and Supplementary Table S1;  $M[SD] = 47.2[8.0]$  years, range 29–60; 58.1% women ( $n = 334$ )). The average TAS-20 total score was 40.8, with subscale means of 11.0 for DIF, 10.4 for DDF, and 19.4 for EOT.

TAS-20 scores were not correlated with age (total  $\rho = -.04$ , DIF  $\rho = -.05$ , DDF  $\rho = -.04$ , EOT  $\rho = .03$ , all  $p > .05$ ), while the total score ( $\rho = .26$ ,  $p = 1.9e-10$ ), DIF ( $\rho = .41$ ,  $p < 2.2e-16$ ), and DDF ( $\rho = .19$ ,  $p = 4.0e-06$ ) were positively correlated with the PHQ-9, but not EOT ( $\rho = .03$ ,  $p > .05$ ).

### Functional connectivity and TAS-20 total score

#### Base model

The TAS-20 total score was associated with altered FC within two clusters: one within the FPN ( $F(3,565) = 8.18$ ,  $p = 8.8e-04$ ; Supplementary Figure S6, Table 3 and Supplementary Table S2), and one between the DAN and SN ( $F(4,564) = 4.88$ ,  $p = .013$ ).

In the first cluster, higher TAS-20 total scores were associated with lower FC between the posterior parietal cortex (PPC) and

lateral prefrontal cortex (LPFC) in both hemispheres and higher interhemispheric LPFC connectivity.

In the second cluster, FC was bilaterally lower between the anterior insula and the intraparietal sulcus (IPS), and between the right frontal eye field (FEF) and right supramarginal gyrus (SMG), alongside higher FC between the left FEF and the bilateral rostral prefrontal cortex (RPFC) and the ACC, and between the left IPS and left RPFC.

#### Fully adjusted model

Controlling for BMI, smoking, alcohol consumption, education, physical activity, partnership status, and depressive symptoms did not substantially change the FC pattern within the FPN (Figure 2, Tables 3 and S2,  $F(3,556) = 7.15$ ,  $p = .004$ ) or between the DAN and SN ( $F(3,556) = 4.01$ ,  $p = .039$ ), only the left IPS–left RPFC association did not survive correction. An additional cluster within the SN revealed lower FC between the right RPFC and both bilateral anterior insulae and SMGs ( $F(3,556) = 4.41$ ,  $p = .029$ ).

### Functional connectivity and DIF

#### Base model

DIF scores were associated with altered FC in four clusters: between the FPN and the SMN ( $F(3, 563) = 6.17$ ,  $p = .003$ ; Supplementary Figure S7, Table 3 and Supplementary Table S3), within the FPN ( $F(3,564) = 6.53$ ,  $p = .004$ ), between the SMN and the SN ( $F(4,563) = 3.84$ ,  $p = .048$ ), and between the DAN and SN ( $F(3,563) = 3.71$ ,  $p = .049$ ).

In the first cluster, higher DIF scores were associated with higher FC between lateral and superior SMN nodes and the left FPN (LPFC, PPC), and between the right LPFC and right lateral SMN.

The second cluster showed higher interhemispheric LPFC connectivity and lower intrahemispheric LPFC–PPC connectivity.

In the third cluster, FC was lower between the left anterior insula and right lateral SMN and between the right anterior insula and

**Table 2.** Sample characteristics

Variable	Selected MRI sample
Sample size with TAS-20 N [%]	575 [42.1%]
Sex - women [%]	334 [58.1%]
Age M [SD]	47.2 [8.0]
Range (min – max)	29–60
BMI M [SD]	26.8 [4.4]
TAS-20*	
Total score M [SD]*	40.8 [8.9]
Range (min–max)*	20–70
Interquartile range (Q1–Q3)*	35–46
DIF M [SD]*	11.0 [4.0]
Range (min–max)*	7–31
DDF M [SD]*	10.4 [3.4]
Range (min–max)*	5–23
EOT M [SD]*	19.4 [4.2]
Range (min–max)*	8–34
Handedness	
Right-handed [%]	514 [89.4%]
Left-handed [%]	27 [4.7%]
Ambidexterity [%]	34 [5.9%]
MRI findings – yes [%]	0 [0.0%]
History of Stroke – yes [%]	0 [0.0%]
PHQ-9 total score M [SD]	3.6 [3.6]
Alcohol consumption g/d M [SD]	10.5 [13.2]
Partnership – yes [%]	453 [78.8%]
Physical active – yes [%]	400 [69.6%]
Educational level Mdn [Q1–Q3]	5 [4–7]
Smoking history	
Never [%]	178 [31.0%]
Former [%]	256 [44.5%]
Current [%]	141 [24.5%]
QC parameters rsfMRI	
Mean motion total M [SD]	0.1 [0.1]
Range (min–max)	0.05–0.31
Max motion total M [SD]	1.0 [0.9]
Range (min–max)	0.13–7.32
Valid scans M [SD]	172.9 [20.3]
Range (min–max)	126–200
Variation BOLD STD M [SD]	0.20 [0.02]
Range (min–max)	0.15–0.25
Degrees of freedom M [SD]	71.5 [10.5]
Range (min–max)	47–85
z-cor MPFC–PCC M [SD]	0.4 [0.2]
Range (min–max)	0.10–0.98

Notes: BMI, body mass index; DDF, difficulties describing feelings; DIF, difficulties identifying feelings; EOT, externally oriented thinking; M, mean; MPFC, ventromedial prefrontal cortex; PCC, posterior cingulate cortex; PHQ-9, patient health questionnaire; QC parameters rsfMRI, quality control parameters derived from resting-state functional magnetic resonance imaging; SD, standard deviation; TAS-20, Toronto Alexithymia Scale.

\*TAS-20 was assessed in SHIP-TREND-0; all other variables were assessed in SHIP-TREND-1.

bilateral lateral SMN, alongside higher FC between the left RPFC and both the left lateral and superior SMN, and between the ACC and superior SMN.

Within the fourth cluster, FC was lower between the left anterior insula and right IPS, alongside higher FC between the left RPFC and bilateral IPS and right FEF, and between the right RPFC and left FEF.

### Fully adjusted model

Two additional clusters emerged, within the SN ( $F(4,555) = 3.95$ ,  $p = .040$ ) and between the CN and FPN ( $F(4,555) = 3.80$ ,  $p = .040$ ), while clusters revealed in the base model remained largely unchanged (Figure 3, Figure 4 for simplified visualization, Table 3 and Supplementary Table S3).

Specifically, higher DIF scores were associated with lower FC between the right RPFC and both bilateral anterior insula and SMG, and between the posterior CN and bilateral PPC and left LPFC.

Minor changes were observed in previously identified clusters: FC between the superior SMN and right RPFC, right RPFC-left FEF, and right LPFC-superior SMN did not survive correction.

### Functional connectivity and DDF

DDF scores were associated with one cluster ( $F(3,565) = 5.71$ ,  $p = .027$ ; Figure 5, Table 3, and Supplementary Table S4), showing higher interhemispheric PPC and LPFC connectivity and lower left PPFC-LPFC connectivity, which was no longer present in the fully adjusted model.

### Functional connectivity and EOT

No EOT-related FC alterations were observed in either model.

### Functional connectivity within the DMN

#### TAS-20 total score

Higher scores were associated with lower left LP-PCC and MPFC-PCC connectivity in both the base ( $F(2,566) = 4.60$ ,  $p = .021$ ; Figure 6A, Table 4) and fully adjusted model ( $F(2,558) = 4.55$ ,  $p = .022$ ; Figure 6B, Table 4).

#### DIF

Higher DIF-scores were associated with lower FC among the left LP, MPFC, and PCC in the base ( $F(2,565) = 5.27$ ,  $p = .011$ ; Figure 6C, Table 4) and fully adjusted model ( $F(2,557) = 4.71$ ,  $p = .017$ ; Figure 6D, Table 4).

## Discussion

Investigating alexithymia-related functional brain networks, we identified distinct alterations within and between networks implicated in emotion processing and attention allocation. To our knowledge, this is the first population-based, whole-brain study to demonstrate such alterations of FC across the alexithymia spectrum, enhancing generalizability.

Higher TAS-20 scores were associated with intra-hemispheric hypoconnectivity between the PPC and LPFC and higher inter-LPFC connectivity within the FPN. The PPC is associated with cognitive processes, including attention shifting and stimulus selection [104–106], whereas the LPFC supports executive control and generates top-down signals that modulate sensory processing and behavior [107–109]. Lower fronto-parietal coupling has been reported in ASD [110], where alexithymia is highly prevalent [19, 36]. As challenges in

**Table 3.** Functional connectivity

Scale	Model	Cluster	Association	<i>F</i>	<i>p</i> uncorrected	<i>p</i> -FDR
TAS-20 total score	Base model	1/36	FPN	8.18	2.4e-05	8.8e-04
		2/36	DAN – SN	4.88	7.1e-04	.013
	Fully adjusted model	1/36	FPN	7.15	1.0e-04	.004
		2/36	SN	4.41	.002	.029
		3/36	DAN – SN	4.01	.003	.039
DIF	Base model	1/36	FPN – SMN	6.17	7.2e-05	.003
		2/36	FPN	6.53	2.4e-04	.004
		3/36	SMN – SN	3.84	.004	.049
		4/36	DAN – SN	3.71	.005	.049
	Fully adjusted model	1/36	FPN	7.60	5.5e-05	.002
		2/36	SMN – SN	4.18	.002	.040
		3/36	SN	3.95	.004	.040
		4/36	FPN – CN	3.80	.005	.040
		5/36	SMN – FPN	3.60	.007	.040
		6/36	DAN – SN	3.60	.007	.040
DDF	Base model	1/36	FPN	5.71	7.5e-04	.027
	Fully adjusted model	<i>n.s.</i>				
EOT	Base model	<i>n.s.</i>				
	Fully adjusted model	<i>n.s.</i>				

Notes: Only significant clusters are presented in the table. Base model, model adjusted for age (linear and quadratic), sex, handedness, and activated coils; CN, cerebellar network; DAN, dorsal attentional network; DDF, difficulties describing feelings; DIF, difficulties identifying feelings; EOT, externally oriented thinking; FPN, frontoparietal network; fully adjusted model, model adjusted for covariates of the base model plus BMI, school years, smoking behavior, alcohol consumption, and current depressive symptoms; *n.s.*, not significant; SMN, sensorimotor network; SN, salience network; TAS-20, Toronto Alexithymia Scale.

emotion recognition are better explained by alexithymia rather than autism [9], the observed FC-pattern overlaps with the underconnectivity theory of autism [110], which proposes reduced long-range cortical and altered large-scale integration within higher-order cognitive control regions.

Besides organic factors (i.e., brain damage), alexithymia may emerge during early childhood due to developmental strains (e.g., negative primary caregiver interactions) [42, 55, 111, 112], potentially moderated by serotonergic genetic variation [113, 114], or later in life following severe stress or trauma [81, 115, 116]. Irrespective of its genesis, alexithymia is associated with attenuated interoception, indicated by worse heartbeat counting performance, which may necessitate compensatory top-down processing to support emotional and behavioral functioning in the absence of reliable bodily signals [32, 53, 117, 118]. This aligns with the original description of alexithymia as focusing on external events while avoiding inner experiences, raising the question of whether it originates from a deficit or an (un)intentional coping strategy [26, 36]. The attention-appraisal model [35] provides a framework, positing differences in emotion valuation that involve both attentional processes (difficulty focusing on emotions) and subsequent appraisal (difficulty identifying and describing emotions). This comprises appropriate responding, as emotion regulation depends on accurate identification of the experienced emotion. Additionally, avoidance of emotions may serve as a short-term regulatory strategy in alexithymia but contributes to persistent deficits and reduced quality of life over time [119–122]. Nevertheless, as the rsfMRI-setting does not explicitly elicit emotions, higher FC in top-down control regions likely reflects an alexithymia-related network

alteration rather than avoidance. The idea of long-term network alteration is further supported by altered DAN-SN connectivity with higher TAS-20 scores. Specifically, frontal SN regions (ACC, RPFC) showed higher coupling with the left DAN, whereas parietal-insular SN regions (anterior insula, SMG) exhibited lower DAN connectivity. This divergence is noteworthy as the anterior insula and ACC have a close functional relationship [123], yet exhibit different coupling patterns. Specifically, the insula plays a crucial role in generating interoceptive awareness of ascending sensory signals, whereas the ACC coordinates responses to interoceptive and exteroceptive events. Together, they form a key node of the SN, which facilitates switching between interoceptive and exteroceptive processing [124, 125]. Accordingly, high-alexithymia individuals showed stronger ACC activation during affective stimulation [53], whereas insular dysfunction underlies altered interoceptive awareness [126]. Given their joint interplay with emotional awareness [30, 123], the observed divergent FC pattern may be associated with its impairment in alexithymia [127–129]. Additionally, we found hyperconnectivity between the frontal SN and left FEF of the DAN, potentially indicating altered network interactions that might be associated with enhanced, possibly compensatory, attention to external stimuli [130, 131].

For DIF, altered FC across the FPN, SN, SMN, CN, and DAN were revealed, even after adjustment for lifestyle factors, health indicators, and depressive symptoms, despite the moderate association between DIF and PHQ-9. These findings suggest that DIF may be linked with network alterations involving interoceptive processing and top-down attentional regulation, potentially contributing to differences in emotional awareness and adaptive

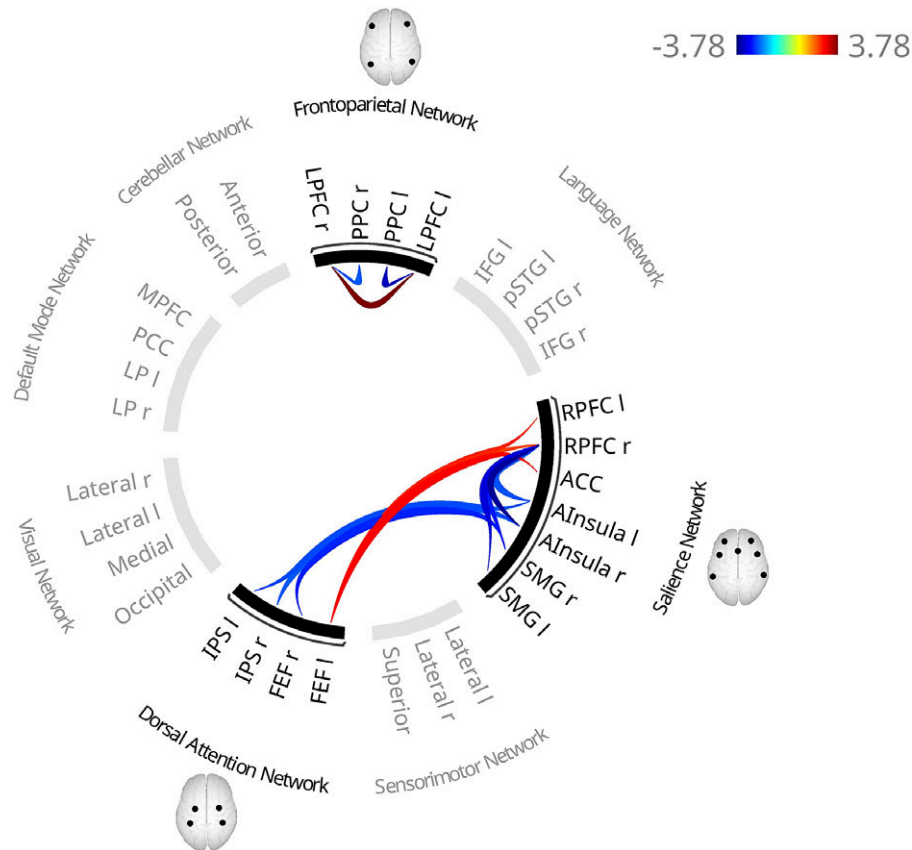

**Figure 2.** Functional connectivity patterns associated with higher TAS-20 total scores in the fully adjusted model. The fully adjusted model includes additional covariates beyond the base model, namely physical activity, relationship status, smoking, depressive symptoms, BMI, and educational level. Red lines indicate higher functional connectivity and blue lines indicate lower functional connectivity associated with higher scores. In contrast to the base model (adjusted for age, sex, coil configuration, and handedness), the larger left IPS–left RPFC association did not survive cluster correction. *Notes:* ACC, anterior cingulate cortex; AInsula, anterior insula; BMI, body mass index; FEF, frontal eye fields; IPS, intraparietal sulcus; l, left; LPFC, lateral prefrontal cortex; PPC, posterior parietal cortex; r, right; RPFC, rostral prefrontal cortex; SMG, supramarginal gyrus; TAS-20, Toronto Alexithymia Scale.

responses to emotional and environmental demands [30]. Additionally, higher DIF was associated with higher FPN-lateral SMN connectivity. Given the SMN's role in primary motor and somatosensory processing [132], this hyperconnectivity may indicate altered network interactions facilitating external attention and top-down regulation [132–134]. This extends the observed divergence between frontal and parietal–insular SN nodes, characterized by lower connectivity between these nodes, hyperconnectivity of the partial-insular node with the DAN and SMN, and hyperconnectivity of frontal SN nodes with these networks. Overall, hypoconnected nodes – including the anterior insula, lateral SMN, SMG, and IPS – may reflect alterations in a sensory-integration network, whereas hyperconnected nodes encompassing the superior SMN, ACC, RPFC, and DAN may indicate an altered executive-control network. This interpretation is further supported by hypoconnectivity between the lateral CN and FPN, suggesting altered cerebellar contributions to frontoparietal network functioning involved in cognitive control and executive processing [135–137].

Unlike DIF, no reliable effects were observed for DDF or EOT. Given the absence of explicit emotional stimulation in the resting-state paradigm, these findings suggest that alexithymia – particularly DIF – modulates attention during rest, potentially reflecting an altered “idle” network organization biased away from interoceptive and emotional signals as they may have less informative value. In contrast, all alexithymia facets are likely more engaged during

active emotional processing [35]. As alexithymia affects processes along the cognition–emotion interface [138], future studies should examine subscale-specific network effects using emotion-eliciting paradigms or clinical samples with higher prevalence, where such alterations may be more pronounced.

Whole-brain analysis showed no DMN alterations associated with alexithymia. Post-hoc analyses showed lower FC between anterior and posterior DMN and the left LP, suggesting altered self-referential processes or self-awareness [139, 140]. As this contrasts with two prior studies [60, 64], possibly due to methodological differences, while others similarly reported no DMN alterations [61] or did it examine the DMN [62, 63], further research is needed to clarify the DMN's role.

## Conclusion

The results indicate that alexithymia is associated with resting-state connectivity alterations at the network-level within and between networks involved in emotion processing and attention, potentially reflecting tonic differences in top-down control, interoception, and attentional allocation. Altered connectivity of the ACC, anterior insula, and frontal regions suggests an altered trait-like large-scale network organization already during the resting (“idling”) state, which may affect adaptive responses to emotional and environmental demands before active emotion processing. Given that

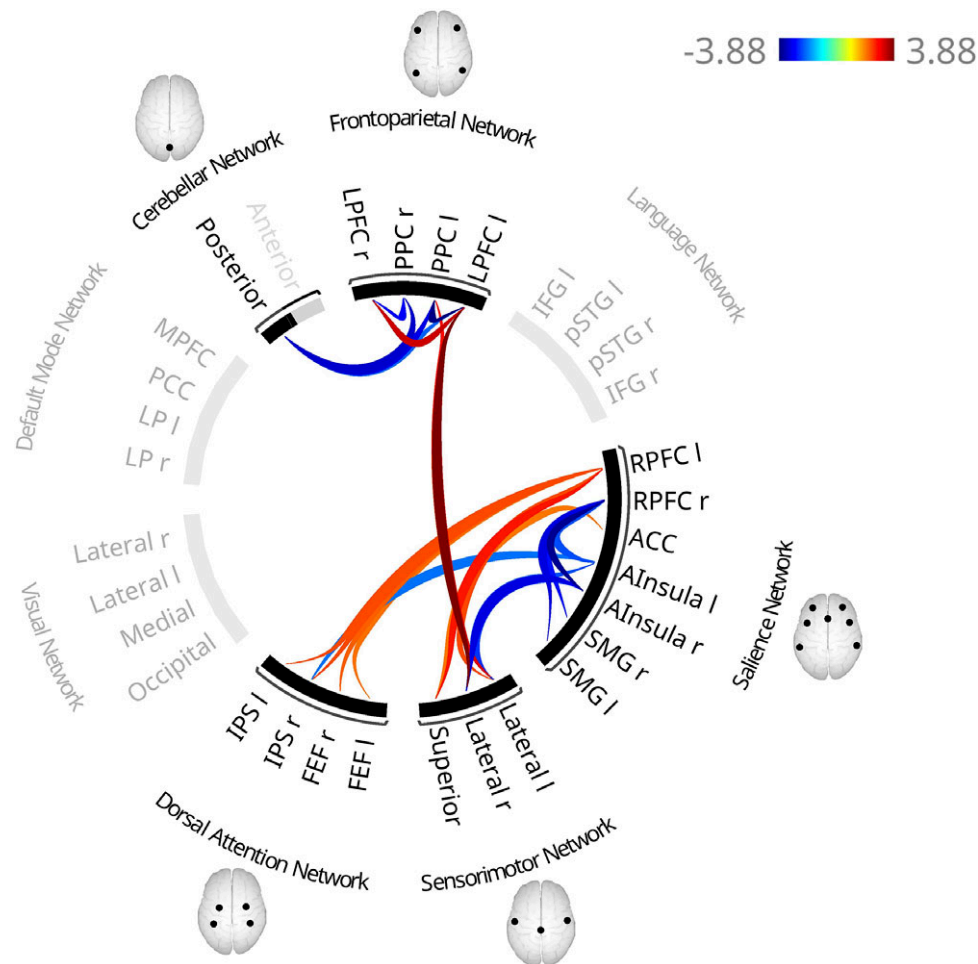

**Figure 3.** Functional connectivity patterns associated with higher scores on the subscale ‘Difficulties Identifying Feelings’ of the 20-item Toronto Alexithymia Scale (TAS-20) in the fully adjusted model. The fully adjusted model includes additional covariates beyond the base model, namely physical activity, relationship status, smoking, depressive symptoms, BMI, and educational level. Red lines indicate higher functional connectivity and blue lines indicate lower functional connectivity associated with higher scores. In contrast to the base model (adjusted for age, sex, coil configuration, and handedness), an additional cluster revealed smaller association between the posterior CN and the bilateral PPC and left LPFC. Additionally, FC was higher between the right RPFC and superior SMN, and between the left RPFC and left FEF. In contrast, the connectivity between the superior SMN and both the left PPC and left LPFC did not survive correction. *Notes:* ACC, anterior cingulate cortex; AInsula, anterior insula; FEF, frontal eye fields; IPS, intraparietal sulcus; l, left; LPFC, lateral prefrontal cortex; PPC, posterior parietal cortex; r, right; RPFC, rostral prefrontal cortex.

alexithymia is a well-established transdiagnostic risk factor across psychopathological and somatic conditions, these network-level alterations may have clinically relevant implications, including risk stratification, understanding patterns of comorbidity and chronic symptom trajectories, and potentially predicting treatment response. Framing alexithymia in terms of large-scale network alterations may therefore help bridge neurobiological findings with clinically relevant outcomes and intervention strategies.

Alexithymia is shaped by early emotional socialization and varies across the lifespan [81, 141], potentially influencing the development of large-scale networks involved in emotional awareness and regulation [124, 142, 143]. Given these networks’ prolonged, experience-sensitive development, future studies should examine altered developmental trajectories, which may contribute to alexithymia-related FC patterns.

### Limitations

ROI-to-ROI analyses capture only linear relationships and lack directionality or causality, limiting interpretability and may oversimplify

brain connectivity. Because adherence to resting-state instructions was not formally assessed, DMN connectivity was used as a proxy to exclude potentially sleeping participants, risking misclassification. Additionally, the absence of physiological recordings may have affected FC estimates [144], and despite artifact-removal procedures, this likely reduced the accuracy of detected FC alterations. Furthermore, some relevant covariates were unavailable (e.g., sleep quality) or had limited granularity.

Excluding participants older than 60 limits interpretation and generalizability across the adult lifespan and socialization histories. The regional scope of SHIP-TREND further constrains generalization to other cultural or geographic populations. Additionally, lower TAS-20 scores compared with other samples [17] may have reduced sensitivity to FC alterations, especially in the DMN.

Although alexithymia is considered a relatively stable personality trait [75–81], the 7- to 8-year gap between alexithymia assessment (SHIP-TREND-0) and rsfMRI (SHIP-TREND-1) may have weakened the reported effects and underestimated the impact on functional networks. Moreover, covariates associated with alexithymia may have changed within individuals over time (e.g., depressive

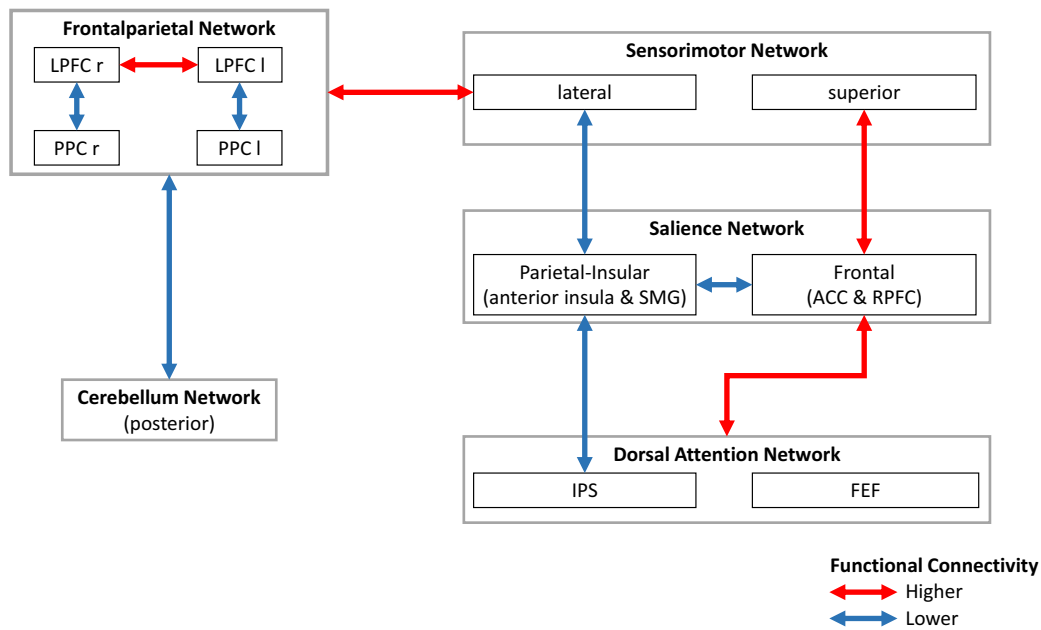

**Figure 4.** Simplified schematic visualization of the functional connectivity pattern associated with higher scores on the subscale “Difficulties Identifying Feelings” of the 20-item Toronto Alexithymia Scale (TAS-20). Notes: ACC, anterior cingulate cortex; FEF, frontal eye fields; IPS, intraparietal sulcus; l, left; LPFC, lateral prefrontal cortex; PPC, posterior parietal cortex; r, right; RPFC, rostral prefrontal cortex; SMG, supramarginal gyrus.

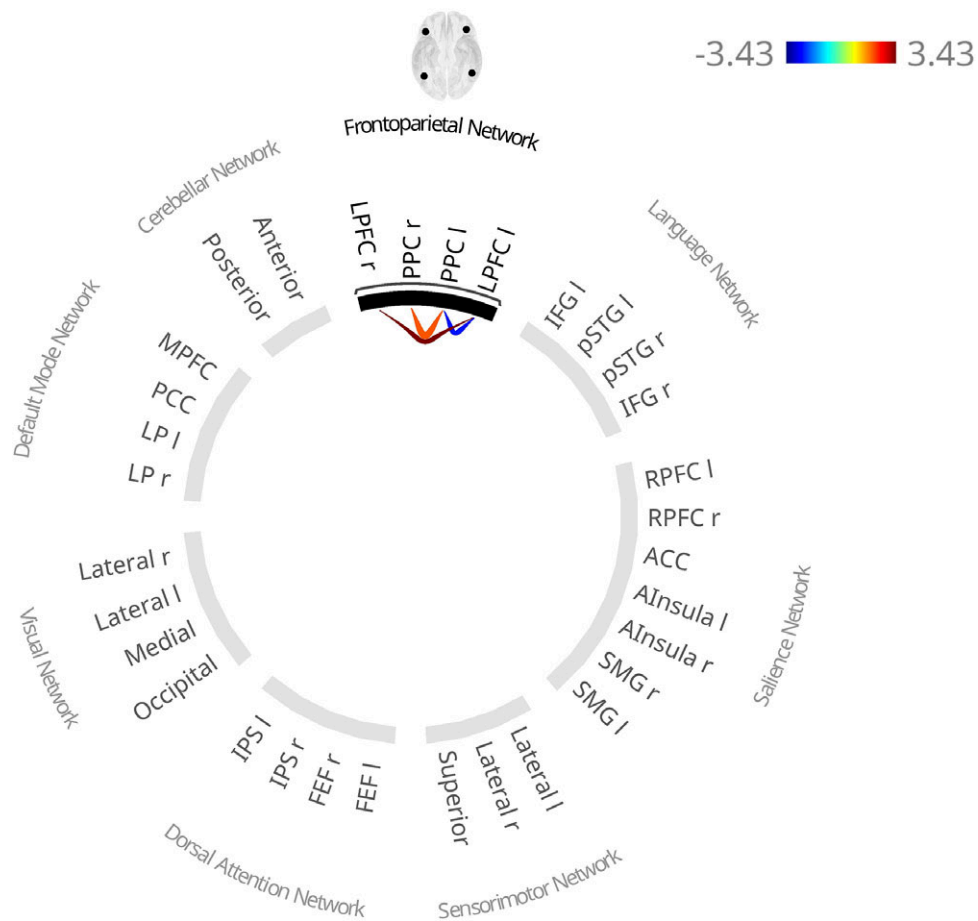

**Figure 5.** Functional connectivity patterns associated with higher scores on the subscale “Difficulties Describing Feelings” of the Toronto Alexithymia Scale (TAS-20) in the base model (adjusted for age, sex, coil configuration, and handedness). Red lines indicate higher functional connectivity and blue lines indicate lower functional connectivity associated with higher scores. Notes: l, left; r, right; LPFC, lateral prefrontal cortex; PPC, posterior parietal cortex.

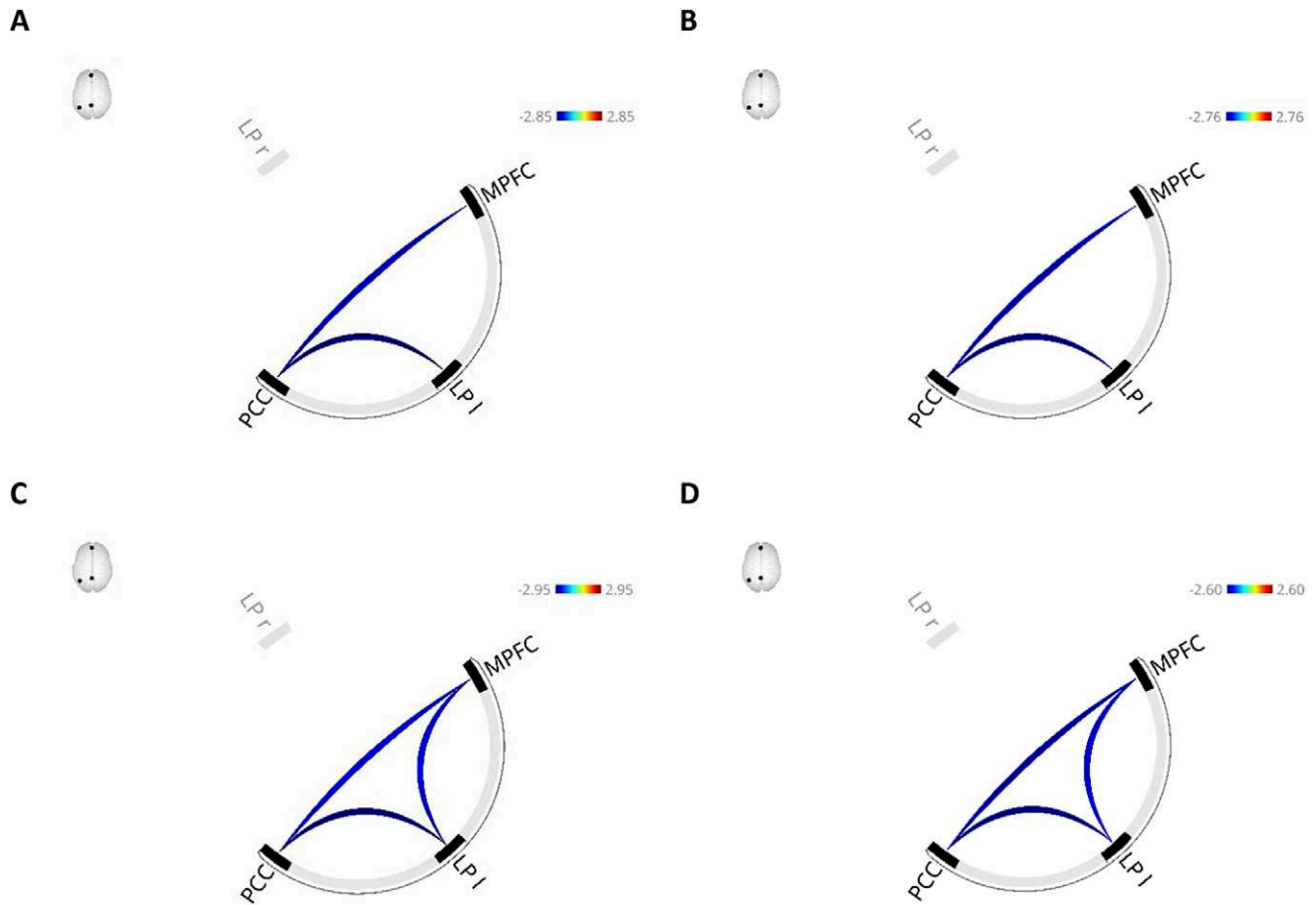

**Figure 6.** Functional connectivity patterns associated with higher Toronto Alexithymia Scale (TAS-20) total scores in the base model (A) and the fully adjusted model (B), and with higher scores on the “Difficulties Identifying Feelings” subscale of the TAS-20 in the base model (C) and the fully adjusted model (D). The base model was adjusted for age, sex, coil configuration, and handedness, while the fully adjusted model additionally included physical activity, relationship status, smoking, depressive symptoms, BMI, and educational level. Red lines indicate higher functional connectivity and blue lines indicate lower functional connectivity associated with higher scores. *Notes:* LP l, left lateral pole; MPFC, medial prefrontal cortex; PCC, posterior parietal cortex.

**Table 4.** Functional connectivity in the default mode network

Scale	Model	Cluster	Association	<i>F</i>	<i>t</i>	<i>p</i> uncorrected	<i>p</i> -FDR
TAS-20 total score	Base model	1/2		4.60		.010	.021
			PCC – LP l	–2.85	4.6e-04	.014	
			PCC – MPFC	–2.44	.015	.023	
	Fully adjusted model	1/2		4.55		.011	.022
			PCC – LP l	–2.76	5.9e-04	.018	
			PCC – MPFC	–2.52	.012	.018	
DIF	Base model	1/2		5.27		.005	.011
			PCC – LP l	–2.95	.003	.010	
			PCC – MPFC	–2.33	.020	.031	
	Fully adjusted model	1/2		4.71		.009	.019
			PCC – LP l	–2.60	.010	.022	
			PCC – MPFC	–2.44	.015	.022	
			MPFC – LP l	–2.21	.027	.041	

*Continued*

**Table 4.** Continued

Scale	Model	Cluster	Association	F	t	p uncorrected	p-FDR
DDF	Base model	n.s.					
	Fully adjusted model	n.s.					
EOT	Base model	n.s.					
	Fully adjusted model	n.s.					

Notes: Only significant clusters are presented in the table. Base model, model adjusted for age (linear and quadratic), sex, handedness, and activated coils; DDF, difficulties describing feelings; DIF, difficulties identifying feelings; EOT, externally oriented thinking; FDR, False Discovery Rate; Fully adjusted model, model adjusted for covariates of the base model plus BMI, educational level, relationship status, physical activity, smoking behavior, alcohol consumption, and current depressive symptoms; LP l, lateral pole left; LP r, lateral pole right; MPFC, medial prefrontal cortex; n.s., not significant; PCC, posterior cingulate cortex; TAS-20, Toronto Alexithymia Scale.

symptoms, alcohol consumption, BMI, smoking behavior), potentially obscuring alexithymia-related FC alterations. As such, we had no information about psychotherapeutic treatment, which could alter alexithymia levels, or anxiety, given its likely impact on alexithymia [145], particularly on DIF. Overall, alexithymia-related FC alterations appeared to be driven by DIF, likely reflecting overlap between DIF items and somatic symptoms rather than emotion processing per se [146].

Although widely used, the TAS-20 has notable limitations, including weak EOT reliability and construct validity, overlap with negative affect, reliance on self-report despite impaired introspection, and limited assessment of affective dimensions [75, 147–149]. Accordingly, future studies may benefit from complementing it with multidimensional instruments, such as the Perth Alexithymia Questionnaire [28].

We used a 1.5 T MRI with a TR of 2.86 s. Although studies using similar settings have demonstrated reproducible resting-state networks [95, 150, 151], this might have affected our results, as newer 3 T scanners with shorter TRs provide higher signal-to-noise ratio, improved spatial and temporal resolution, and enhanced BOLD contrast [152–154].

## Abbreviations

ACC	anterior cingulate cortex
ASD	autism spectrum disorder
BMI	body mass index
BOLD	blood oxygenation level-dependent
CN	cerebellar network
DAN	dorsal attention network
DDF	difficulties describing feelings
DIF	difficulties identifying feelings
DMN	default mode network
EOT	externally oriented thinking
EPI	echo-planar imaging
FEF	frontal eye field
FPN	frontoparietal network
ICA	independent component analysis
IFG	inferior frontal gyrus
IPS	intraparietal sulcus
IQR	interquartile range
LPFC	lateral prefrontal cortex
MNI	Montreal Neurological Institute
PHQ-9	patient health questionnaire
PPC	posterior parietal cortex
ROI	region of interest
RPFC	rostral prefrontal cortex
SMG	supramarginal gyrus
SMN	sensorimotor network
SN	salience network

STG	superior temporal gyrus
TAS-20	20-item Toronto Alexithymia Scale
TE	echo time
TR	repetition time
MPFC	medial prefrontal cortex

**Supplementary material.** The supplementary material for this article can be found at <http://doi.org/10.1192/j.eurpsy.2026.10177>.

**Data availability statement.** The data from the SHIP study cannot be made publicly available due to the informed consent of the study participants; however, it can be accessed through a data application form available at <https://fvcm.med.unigreifswald.de/> for researchers who meet the criteria for access to confidential data.

**Acknowledgements.** The authors would like to sincerely thank everyone who participated in SHIP-TREND.

**Author contribution.** E.K., J.K.K. and H.J.G. designed the project. All co-authors contributed to the acquisition, analysis or interpretation of the data. E.K. and J.K.K. drafted the manuscript, while all other coauthors critically reviewed it. E.K. and J.K.K. conceived and conducted the statistical analyses with support from S.F., M.O.W., H.V., R.B., and H.J.G. were involved in data curation, administrative, technical, or material support, or funding acquisition. H.J.G. supervised the project. All authors have read and approved the submitted version of the manuscript.

**Financial support.** SHIP is part of the Community Medicine Research net of the University of Greifswald, Germany, which is funded by the Federal Ministry of Education and Research (grants no. 01ZZ9603, 01ZZ0103, and 01ZZ0403), the Ministry of Cultural Affairs as well as the Social Ministry of the Federal State of Mecklenburg-West Pomerania, and the network 'Greifswald Approach to Individualized Medicine (GANI\_MED)' funded by the Federal Ministry of Education and Research (grant 03IS2061A).

Whole-body MR imaging was supported by a joint grant from Siemens Healthineers, Erlangen, Germany and the Federal State of Mecklenburg West Pomerania.

**Competing interests.** H.J.G. has received travel grants and speakers honoraria from Neuraxpharm, Servier, Indorsia and Janssen Cilag. All other authors reported no financial interests or other potential conflicts of interest.

**Statement of ethics.** Study approval statement: The studies were approved by the Ethics Committee at the University Medicine Greifswald, Germany (approval number BB 39/08).

Consent to participate statement: Oral and written informed consents were obtained from all participants according to the principles of the Declaration of Helsinki.

**Declaration of generative AI and AI-assisted technologies in the writing process.** ChatGPT was used to improve the clarity and readability of this work. Afterwards, we carefully reviewed and edited the text and take full responsibility for the final content.

## References

- [1] Taylor GJ, Porcelli P, Bagby RM. Alexithymia: a Defense of the original conceptualization of the construct and a critique of the attention-appraisal model. *Clin Neuropsychiatry*. 2024;21:329–57. <https://doi.org/10.36131/cnfioritieditore20240501>.
- [2] Preece DA, Gross JJ. Conceptualizing alexithymia. *Personal Individ Differ*. 2023;215:112375. <https://doi.org/10.1016/j.paid.2023.112375>.
- [3] Vorst HCM, Bermond B. Validity and reliability of the Bermond–Vorst alexithymia questionnaire. *Personal Individ Differ*. 2001;30:413–34. [https://doi.org/10.1016/S0191-8869\(00\)00033-7](https://doi.org/10.1016/S0191-8869(00)00033-7).
- [4] Nemiah JC. Alexithymia. *Psychother Psychosom*. 1977;28:199–206. <https://doi.org/10.1159/000287064>.
- [5] Di Tella M, Benfante A, Airale L, Castelli L, Milan A. Alexithymia and hypertension: does personality matter? A systematic review and meta-analysis. *Curr Cardiol Rep*. 2023;25:711–24. <https://doi.org/10.1007/s11886-023-01894-7>.
- [6] Grabe HJ, Schwahn C, Barnow S, Spitzer C, John U, Freyberger HJ, et al. Alexithymia, hypertension, and subclinical atherosclerosis in the general population. *J Psychosom Res*. 2010;68:139–47. <https://doi.org/10.1016/j.jpsychores.2009.07.015>.
- [7] Vadini F, Lanzara R, Iuliani O, Affaitati GP, Porcelli P. Alexithymia and estimated 10-year cardiovascular disease risk in healthy adults: a community-based cross-sectional study. *Front Psychol*. 2024;15:1504143. <https://doi.org/10.3389/fpsyg.2024.1504143>.
- [8] Terock J, Klinger-König J, Janowitz D, Nauck M, Völzke H, Grabe HJ. Alexithymia is associated with increased all-cause mortality risk in men, but not in women: a 10-year follow-up study. *J Psychosom Res*. 2021;143:110372. <https://doi.org/10.1016/j.jpsychores.2021.110372>.
- [9] Bird G, Cook R. Mixed emotions: the contribution of alexithymia to the emotional symptoms of autism. *Transl Psychiatry*. 2013;3:e285. <https://doi.org/10.1038/tp.2013.61>.
- [10] Kojima M. Alexithymia as a prognostic risk factor for health problems: a brief review of epidemiological studies. *Biopsychosoc Med*. 2012;6:21. <https://doi.org/10.1186/1751-0759-6-21>.
- [11] Leweke F, Leichsenring F, Kruse J, Hermes S. Is alexithymia associated with specific mental disorders. *Psychopathology*. 2012;45:22–8. <https://doi.org/10.1159/000325170>.
- [12] Porcelli P, Taylor GJ. Alexithymia and physical illness: a psychosomatic approach. In: Luminet O, Bagby RM, Taylor GJ, editors. *Alexithymia*. 1st ed. Cambridge University Press; 2018, pp. 105–26. <https://doi.org/10.1017/9781108241595.009>.
- [13] Preece DA, Mehta A, Petrova K, Sikka P, Bjureberg J, Chen W, et al. The Perth alexithymia questionnaire-short form (PAQ-S): a 6-item measure of alexithymia. *J Affect Disord*. 2023;325:493–501. <https://doi.org/10.1016/j.jad.2023.01.036>.
- [14] Putica A, Van Dam NT, Felmingham K, Lawrence-Wood E, McFarlane A, O'Donnell M. Interactive relationship between alexithymia, psychological distress and posttraumatic stress disorder symptomology across time. *Cogn Emot*. 2024;38:232–44. <https://doi.org/10.1080/0269931.2023.2283934>.
- [15] Grabe HJ, Frommer J, Ankerhold A, Ulrich C, Gröger R, Franke GH, et al. Alexithymia and outcome in psychotherapy. *Psychother Psychosom*. 2008;77:189–94. <https://doi.org/10.1159/000119739>.
- [16] Lumley MA, Neely LC, Burger AJ. The assessment of alexithymia in medical settings: implications for understanding and treating health problems. *J Pers Assess*. 2007;89:230–46. <https://doi.org/10.1080/00223890701629698>.
- [17] Franz M, Popp K, Schaefer R, Sitte W, Schneider C, Hardt J, et al. Alexithymia in the German general population. *Soc Psychiatry Psychiatr Epidemiol*. 2008;43:54–62. <https://doi.org/10.1007/s00127-007-0265-1>.
- [18] Honkalampi K, Koivumaa-Honkanen H, Tanskanen A, Hintikka J, Lehtonen J, Viinamäki H. Why do Alexithymic features appear to be stable? *Psychother Psychosom*. 2001;70:247–53. <https://doi.org/10.1159/000056262>.
- [19] Kinnaird E, Stewart C, Tchanturia K. Investigating alexithymia in autism: a systematic review and meta-analysis. *Eur Psychiatry*. 2019;55:80–9. <https://doi.org/10.1016/j.eurpsy.2018.09.004>.
- [20] McGillivray L, Becerra R, Harms C. Prevalence and demographic correlates of alexithymia: a comparison between Australian psychiatric and community samples. *J Clin Psychol*. 2017;73:76–87. <https://doi.org/10.1002/jclp.22314>.
- [21] Salminen JK, Saarijärvi S, Äärelä E, Toikka T, Kauhanen J. Prevalence of alexithymia and its association with sociodemographic variables in the general population of Finland. *J Psychosom Res*. 1999;46:75–82. [https://doi.org/10.1016/S0022-3999\(98\)00053-1](https://doi.org/10.1016/S0022-3999(98)00053-1).
- [22] Honkalampi K, Hintikka J, Tanskanen A, Lehtonen J, Viinamäki H. Depression is strongly associated with alexithymia in the general population. *J Psychosom Res*. 2000;48:99–104. [https://doi.org/10.1016/S0022-3999\(99\)00083-5](https://doi.org/10.1016/S0022-3999(99)00083-5).
- [23] Bach M, Bach D, de Zwaan M, Serim M, Böhmer F. [validation of the German version of the 20-item Toronto alexithymia scale in normal persons and psychiatric patients]. *Psychother Psychosom Med Psychol*. 1996;46:23–8.
- [24] Bagby RM, Parker JDA, Taylor GJ. The twenty-item Toronto alexithymia scale – I. Item selection and cross-validation of the factor structure. *J Psychosom Res*. 1994;38:23–32. [https://doi.org/10.1016/0022-3999\(94\)90005-1](https://doi.org/10.1016/0022-3999(94)90005-1).
- [25] Bagby RM, Taylor GJ, Parker JDA. The twenty-item Toronto alexithymia scale – II. Convergent, discriminant, and concurrent validity. *J Psychosom Res*. 1994;38:33–40. [https://doi.org/10.1016/0022-3999\(94\)90006-x](https://doi.org/10.1016/0022-3999(94)90006-x).
- [26] Sifneos PE. The prevalence of 'Alexithymic' characteristics in psychosomatic patients. *Psychother Psychosom*. 1973;22:255–62. <https://doi.org/10.1159/000286529>.
- [27] Bermond B, Vorst HCM, Vingerhoets AJJM, Gerritsen W. The Amsterdam alexithymia scale: its psychometric values and correlations with other personality traits. *Psychother Psychosom*. 1999;68:241–51. <https://doi.org/10.1159/000012340>.
- [28] Preece D, Becerra R, Robinson K, Dandy J, Allan A. The psychometric assessment of alexithymia: development and validation of the Perth alexithymia questionnaire. *Personal Individ Differ*. 2018;132:32–44. <https://doi.org/10.1016/j.paid.2018.05.011>.
- [29] Brewer R, Cook R, Bird G. Alexithymia: a general deficit of interoception. *R Soc Open Sci*. 2016;3:150664. <https://doi.org/10.1098/rsos.150664>.
- [30] Craig AD. How do you feel – now? The anterior insula and human awareness. *Nat Rev Neurosci*. 2009;10:59–70. <https://doi.org/10.1038/nrn2555>.
- [31] Craig AD. How do you feel? Interoception: the sense of the physiological condition of the body. *Nat Rev Neurosci*. 2002;3:655–66. <https://doi.org/10.1038/nrn894>.
- [32] Murphy J, Catmur C, Bird G. Alexithymia is associated with a multi-domain, multidimensional failure of interoception: evidence from novel tests. *J Exp Psychol Gen*. 2018;147:398–408. <https://doi.org/10.1037/xge0000366>.
- [33] Garfinkel SN, Critchley HD. Interoception, emotion and brain: new insights link internal physiology to social behaviour. Commentary on: Soc Cogn Affect Neurosci. 2013;8:231–4. <https://doi.org/10.1093/scan/nss140>.
- [34] Terasawa Y, Shibata M, Moriguchi Y, Umeda S. Anterior insular cortex mediates bodily sensibility and social anxiety. *Soc Cogn Affect Neurosci*. 2013;8:259–66. <https://doi.org/10.1093/scan/nss108>.
- [35] Preece DA, Becerra R, Allan A, Robinson K, Dandy J. Establishing the theoretical components of alexithymia via factor analysis: introduction and validation of the attention-appraisal model of alexithymia. *Personal Individ Differ*. 2017;119:341–52. <https://doi.org/10.1016/j.paid.2017.08.003>.
- [36] Hogeveen J, Grafman J. Alexithymia. *Handb Clin Neurol*. 2021;183:47–62. <https://doi.org/10.1016/B978-0-12-822290-4.00004-9>.
- [37] Preece DA, Mehta A, Becerra R, Chen W, Allan A, Robinson K, et al. Why is alexithymia a risk factor for affective disorder symptoms? The role of emotion regulation. *J Affect Disord*. 2022;296:337–41. <https://doi.org/10.1016/j.jad.2021.09.085>.
- [38] Lischke A, Pahnke R, Mau-Moeller A, Behrens M, Grabe HJ, Freyberger HJ, et al. Inter-individual differences in heart rate variability are associated with inter-individual differences in empathy and alexithymia. *Front Psychol*. 2018;9:229. <https://doi.org/10.3389/fpsyg.2018.00229>.

- [39] Härtwig EA, Aust S, Heuser I. HPA system activity in alexithymia: a cortisol awakening response study. *Psychoneuroendocrinology*. 2013;38:2121–6. <https://doi.org/10.1016/j.psyneuen.2013.03.023>.
- [40] Goerlich KS, Votinov M. Hormonal abnormalities in alexithymia. *Front Psych*. 2023;13:1070066. <https://doi.org/10.3389/fpsy.2022.1070066>.
- [41] Carta MG, Sancassiani F, Pippia V, Bhat KM, Sardu C, Meloni L. Alexithymia is associated with delayed treatment seeking in acute myocardial infarction. *Psychother Psychosom*. 2013;82:190–2. <https://doi.org/10.1159/000341181>.
- [42] Wearden A, Cook L, Vaughan-Jones J. Adult attachment, alexithymia, symptom reporting, and health-related coping. *J Psychosom Res*. 2003;55:341–7. [https://doi.org/10.1016/S0022-3999\(02\)00635-9](https://doi.org/10.1016/S0022-3999(02)00635-9).
- [43] Carrozzino D, Porcelli P. Alexithymia in gastroenterology and hepatology: a systematic review. *Front Psychol*. 2018;9:470. <https://doi.org/10.3389/fpsyg.2018.00470>.
- [44] Grabe HJ, Spitzer C, Freyberger HJ. Alexithymia and personality in relation to dimensions of psychopathology. *Am J Psychiatry*. 2004;161:1299–301. <https://doi.org/10.1176/appi.ajp.161.7.1299>.
- [45] Honkalampi K, Hintikka J, Laukkanen E, Viinamäki JH. Alexithymia and depression: a prospective study of patients with major depressive disorder. *Psychosomatics*. 2001;42:229–34. <https://doi.org/10.1176/appi.psy.42.3.229>.
- [46] Klinger-König J, Hertel J, Terock J, Völzke H, Van Der Auwera S, Grabe HJ. Predicting physical and mental health symptoms: additive and interactive effects of difficulty identifying feelings, neuroticism and extraversion. *J Psychosom Res*. 2018;115:14–23. <https://doi.org/10.1016/j.jpsychores.2018.10.003>.
- [47] Zeitlin SB, McNally RJ. Alexithymia and anxiety sensitivity in panic disorder and obsessive-compulsive disorder. *Am J Psychiatry*. 1993;150:658–60. <https://doi.org/10.1176/ajp.150.4.658>.
- [48] De Gucht V, Heiser W. Alexithymia and somatisation. *J Psychosom Res*. 2003;54:425–34. [https://doi.org/10.1016/S0022-3999\(02\)00467-1](https://doi.org/10.1016/S0022-3999(02)00467-1).
- [49] Mahapatra A, Sharma P. Association of Internet addiction and alexithymia – a scoping review. *Addict Behav*. 2018;81:175–82. <https://doi.org/10.1016/j.addbeh.2018.02.004>.
- [50] Kun B, Alpay P, Bodó V, Molnár Á, Horváth A, Karsai S, et al. Differences in the associations between psychoactive substance use and alexithymia: a series of meta-analyses. *Clin Psychol Rev*. 2023;103:102297. <https://doi.org/10.1016/j.cpr.2023.102297>.
- [51] Thorberg FA, Young RMD, Sullivan KA, Lyvers M. Alexithymia and alcohol use disorders: a critical review. *Addict Behav*. 2009;34:237–45. <https://doi.org/10.1016/j.addbeh.2008.10.016>.
- [52] Li S, Zhang B, Guo Y, Zhang J. The association between alexithymia as assessed by the 20-item Toronto alexithymia scale and depression: a meta-analysis. *Psychiatry Res*. 2015;227:1–9. <https://doi.org/10.1016/j.psychres.2015.02.006>.
- [53] Van Der Velde J, Servaas MN, Goerlich KS, Bruggeman R, Horton P, Costafreda SG, et al. Neural correlates of alexithymia: a meta-analysis of emotion processing studies. *Neurosci Biobehav Rev*. 2013;37:1774–85. <https://doi.org/10.1016/j.neubiorev.2013.07.008>.
- [54] Xu P, Opmeer EM, Van Tol M-J, Goerlich KS, Aleman A. Structure of the alexithymic brain: a parametric coordinate-based meta-analysis. *Neurosci Biobehav Rev*. 2018;87:50–5. <https://doi.org/10.1016/j.neubiorev.2018.01.004>.
- [55] Goerlich KS. The multifaceted nature of alexithymia – a neuroscientific perspective. *Front Psychol*. 2018;9:1614. <https://doi.org/10.3389/fpsyg.2018.01614>.
- [56] Goerlich-Dobre KS, Bruce L, Martens S, Aleman A, Hooker CI. Distinct associations of insula and cingulate volume with the cognitive and affective dimensions of alexithymia. *Neuropsychologia*. 2014;53:284–92. <https://doi.org/10.1016/j.neuropsychologia.2013.12.006>.
- [57] Grabe HJ, Wittfeld K, Hegenscheid K, Hosten N, Lotze M, Janowitz D, et al. Alexithymia and brain gray matter volumes in a general population sample: alexithymia and Gray matter. *Hum Brain Mapp*. 2014;35:5932–45. <https://doi.org/10.1002/hbm.22595>.
- [58] Ihme K, Dannlowski U, Lichev V, Stuhmann A, Grotegerd D, Rosenberg N, et al. Alexithymia is related to differences in gray matter volume: a voxel-based morphometry study. *Brain Res*. 2013;1491:60–7. <https://doi.org/10.1016/j.brainres.2012.10.044>.
- [59] Terock J, Frenzel S, Wittfeld K, Klinger-König J, Janowitz D, Bülow R, et al. Alexithymia is associated with altered cortical thickness networks in the general population. *Neuropsychobiology*. 2020;79:233–44. <https://doi.org/10.1159/000504983>.
- [60] Liemburg EJ, Swart M, Bruggeman R, Kortekaas R, Knegtering H, Čurčić-Blake B, et al. Altered resting state connectivity of the default mode network in alexithymia. *Soc Cogn Affect Neurosci*. 2012;7:660–6. <https://doi.org/10.1093/scan/nss048>.
- [61] Han D, Li M, Mei M, Sun X. The functional and structural characteristics of the emotion network in alexithymia. *Neuropsychiatr Dis Treat*. 2018;14:991–8. <https://doi.org/10.2147/NDT.S154601>.
- [62] Kim N, Park I, Lee YJ, Jeon S, Kim S, Lee KH, et al. Alexithymia and frontal-amygdala functional connectivity in north Korean refugees. *Psychol Med*. 2020;50:334–41. <https://doi.org/10.1017/S0033291719000175>.
- [63] Li X, Peng C, Qin F, Luo Q, Ren Z, Wang X, et al. Basolateral amygdala functional connectivity in alexithymia: linking interoceptive sensibility and cognitive empathy. *Neuroscience*. 2024;539:12–20. <https://doi.org/10.1016/j.neuroscience.2023.12.014>.
- [64] Sutherland MT, Carroll AJ, Salmeron BJ, Ross TJ, Stein EA. Insula's functional connectivity with ventromedial prefrontal cortex mediates the impact of trait alexithymia on state tobacco craving. *Psychopharmacology*. 2013;228:143–55. <https://doi.org/10.1007/s00213-013-3018-8>.
- [65] Shokri-Kojori E, Tomasi D, Volkow ND. An autonomic network: synchrony between slow rhythms of pulse and brain resting state is associated with personality and emotions. *Cereb Cortex*. 2018;28:3356–71. <https://doi.org/10.1093/cercor/bhy144>.
- [66] Cremona S, Gillig A, Mellet E, Joliet M. A dynamic framework of brain functional patterns shaped by spontaneous thoughts beyond the default mode network. *Sci Rep*. 2025;15:28389. <https://doi.org/10.1038/s41598-025-10432-0>.
- [67] Deco G, Jirsa VK, McIntosh AR. Emerging concepts for the dynamical organization of resting-state activity in the brain. *Nat Rev Neurosci*. 2011;12:43–56. <https://doi.org/10.1038/nrn2961>.
- [68] Völzke H, Schössow J, Schmidt CO, Jürgens C, Richter A, Werner A, et al. Cohort profile update: the study of health in Pomerania (SHIP). *Int J Epidemiol*. 2022;51:e372–83. <https://doi.org/10.1093/ije/dyac034>.
- [69] Hosten N, Bülow R, Völzke H, Domin M, Schmidt CO, Teumer A, et al. SHIP-MR and radiology: 12 years of whole-body magnetic resonance imaging in a single Center. *Healthcare*. 2021;10:33. <https://doi.org/10.3390/healthcare10010033>.
- [70] Jöckel KH, Babitsch B, Bellach B-M. Messung und Quantifizierung soziodemographischer Merkmale in epidemiologischen Studien. *Mess. Soziographischer Merkmale Epidemiol*. München: MMV Medizin Verlag; 1998, pp. 7–38.
- [71] Mielck A. Soziale Ungleichheit und gesundheit: empirische Ergebnisse, Erklärungsansätze, Interventionsmöglichkeiten. 1st Auflage. Bern Göttingen Toronto Seattle: Verlag Hans Huber; 2000.
- [72] Gräfe K, Zipfel S, Herzog W, Löwe B. Screening psychischer Störungen mit dem "Gesundheitsfragebogen für Patienten (PHQ-D)". *Diagnostica*. 2004;50:171–81. <https://doi.org/10.1026/0012-1924.50.4.171>.
- [73] Kroenke K, Spitzer RL, Williams JBW. The PHQ-9: validity of a brief depression severity measure. *J Gen Intern Med*. 2001;16:606–13. <https://doi.org/10.1046/j.1525-1497.2001.016009606.x>.
- [74] Taylor GJ, Bagby RM, Parker JDA. The 20-item Toronto alexithymia scale. *J Psychosom Res*. 2003;55:277–83. [https://doi.org/10.1016/S0022-3999\(02\)00601-3](https://doi.org/10.1016/S0022-3999(02)00601-3).
- [75] Bagby RM, Parker JDA, Taylor GJ. Twenty-five years with the 20-item Toronto alexithymia scale. *J Psychosom Res*. 2020;131:109940. <https://doi.org/10.1016/j.jpsychores.2020.109940>.
- [76] De Gucht V, Fontaine J, Fischler B. Temporal stability and differential relationships with neuroticism and extraversion of the three subscales of the 20-item Toronto alexithymia scale in clinical and nonclinical samples. *J Psychosom Res*. 2004;57:25–33. [https://doi.org/10.1016/S0022-3999\(03\)00577-4](https://doi.org/10.1016/S0022-3999(03)00577-4).
- [77] Hiirola A, Pirkola S, Karukivi M, Markkula N, Bagby R, Joukamaa M, et al. An evaluation of the absolute and relative stability of alexithymia

- over 11 years in a Finnish general population. *J Psychosom Res.* 2017;95:81–7. <https://doi.org/10.1016/j.jpsychores.2017.02.007>.
- [78] Luminet O, Bagby RM, Taylor GJ. An evaluation of the absolute and relative stability of alexithymia in patients with major depression. *Psychother Psychosom.* 2001;70:254–60. <https://doi.org/10.1159/000056263>.
- [79] Picardi A, Toni A, Caroppo E. Stability of alexithymia and its relationships with the 'big five' factors, temperament, character, and attachment style. *Psychother Psychosom.* 2005;74:371–8. <https://doi.org/10.1159/000087785>.
- [80] Rufer M, Ziegler A, Alsleben H, Fricke S, Ortman J, Brückner E, et al. A prospective long-term follow-up study of alexithymia in obsessive-compulsive disorder. *Compr Psychiatry.* 2006;47:394–8. <https://doi.org/10.1016/j.comppsy.2005.12.004>.
- [81] Taylor GJ, Bagby RM, Parker JDA, Grotstein J. Disorders of affect regulation: alexithymia in medical and psychiatric illness. 1st ed. Cambridge: Cambridge University Press; 1997. <https://doi.org/10.1017/CBO9780511526831>.
- [82] Hegenscheid K, Kühn J, Völzke H, Biffar R, Hosten N, Puls R. Whole-body magnetic resonance imaging of healthy volunteers: pilot study results from the population-based SHIP study. *RöFo - Fortschritte Auf Dem Geb Röntgenstrahlen Bildgeb Verfahren.* 2009;181:748–59. <https://doi.org/10.1055/s-0028-1109510>.
- [83] Esteban O, Markiewicz CJ, Blair RW, Moodie CA, Isik AI, Erramuzpe A, et al. fMRIPrep: a robust preprocessing pipeline for functional MRI. *Nat Methods.* 2019;16:1111–6. <https://doi.org/10.1038/s41592-018-0235-4>.
- [84] Nieto-Castanon A. Handbook of functional connectivity magnetic resonance imaging methods in CONN. Boston, MA: Hilbert Press; 2020.
- [85] Nieto-Castanon A, Whitfield-Gabrieli S. CONN functional connectivity toolbox: RRID SCR\_009550, release 22. 22nd ed. Hilbert Press; 2022. <https://doi.org/10.56441/hilbertpress.2246.5840>.
- [86] Nieto-Castanon A. Preparing fMRI data for statistical analysis; 2022. <https://doi.org/10.48550/ARXIV.2210.13564>.
- [87] Horovitz SG, Braun AR, Carr WS, Picchioni D, Balkin TJ, Fukunaga M, et al. Decoupling of the brain's default mode network during deep sleep. *Proc Natl Acad Sci.* 2009;106:11376–81. <https://doi.org/10.1073/pnas.0901435106>.
- [88] Henson RN, Olszowy W, Tsvetanov KA, Yadav PS, Cam-CAN, Zeidman P. Evaluating models of the ageing BOLD response. *Hum Brain Mapp.* 2024;45. <https://doi.org/10.1002/hbm.70043>.
- [89] Tsvetanov KA, Henson RNA, Jones PS, Mutsaerts H, Fuhrmann D, Tyler LK, et al. The effects of age on resting-state BOLD signal variability is explained by cardiovascular and cerebrovascular factors. *Psychophysiology.* 2021;58. <https://doi.org/10.1111/psyp.13714>.
- [90] Yabluchanskiy A, Nyul-Toth A, Csiszar A, Gulej R, Saunders D, Towner R, et al. Age-related alterations in the cerebrovasculature affect neurovascular coupling and BOLD fMRI responses: insights from animal models of aging. *Psychophysiology.* 2021;58. <https://doi.org/10.1111/psyp.13718>.
- [91] Grady CL, Protzner AB, Kovacevic N, Strother SC, Afshin-Pour B, Wojtowicz M, et al. A multivariate analysis of age-related differences in default mode and task-positive networks across multiple cognitive domains. *Cereb Cortex.* 2010;20:1432–47. <https://doi.org/10.1093/cercor/bhp207>.
- [92] Persson J, Lustig C, Nelson JK, Reuter-Lorenz PA. Age differences in deactivation: a link to cognitive control? *J Cogn Neurosci.* 2007;19:1021–32. <https://doi.org/10.1162/jocn.2007.19.6.1021>.
- [93] Campbell KL, Grigg O, Saverino C, Churchill N, Grady CL. Age differences in the intrinsic functional connectivity of default network subsystems. *Front Aging Neurosci.* 2013;5. <https://doi.org/10.3389/fnagi.2013.00073>.
- [94] Andrews-Hanna JR, Snyder AZ, Vincent JL, Lustig C, Head D, Raichle ME, et al. Disruption of large-scale brain systems in Advanced Aging. *Neuron.* 2007;56:924–35. <https://doi.org/10.1016/j.neuron.2007.10.038>.
- [95] Damoiseaux JS, Rombouts SARB, Barkhof F, Scheltens P, Stam CJ, Smith SM, et al. Consistent resting-state networks across healthy subjects. *Proc Natl Acad Sci USA.* 2006;103:13848–53. <https://doi.org/10.1073/pnas.0601417103>.
- [96] Chow R, Rabi R, Paracha S, Hasher L, Anderson ND, Alain C. Default mode network and neural phase synchronization in healthy aging: a resting state EEG study. *Neuroscience.* 2022;485:116–28. <https://doi.org/10.1016/j.neuroscience.2022.01.008>.
- [97] Fan J, Juttukonda MR, Goodale SE, Wang S, Orbán C, Varadarajan D, et al. Functional MRI signatures of autonomic physiology in aging. *Commun Biol.* 2025;8:1287. <https://doi.org/10.1038/s42003-025-08703-7>.
- [98] Jafri MJ, Pearlson GD, Stevens M, Calhoun VD. A method for functional network connectivity among spatially independent resting-state components in schizophrenia. *NeuroImage.* 2008;39:1666–81. <https://doi.org/10.1016/j.neuroimage.2007.11.001>.
- [99] Benjamini Y, Hochberg Y. Controlling the false discovery rate: a practical and powerful approach to multiple testing. *J R Stat Soc Ser B Stat Methodol.* 1995;57:289–300. <https://doi.org/10.1111/j.2517-6161.1995.tb02031.x>.
- [100] Ramzi NH, Auvinen J, Veijola J, Miettunen J, Ala-Mursula L, Sebert S, et al. Depression mediates the relationship between alexithymia and obesity in the northern Finland birth cohort 1966 (NFBC1966). *J Affect Disord.* 2023;331:1–7. <https://doi.org/10.1016/j.jad.2023.03.026>.
- [101] Grabowska P, Targowski T, Rozyńska R, Mierzejewska J, From S. Alexithymia and depression: relationship to cigarette smoking, nicotine dependence and motivation to quit smoking. *Przegl Lek.* 2005;62:1004–6.
- [102] Lyvers M, Pickett L, Needham K, Thorberg FA. Alexithymia, fear of intimacy, and relationship satisfaction. *J Fam Issues.* 2022;43:1068–89. <https://doi.org/10.1177/0192513X211010206>.
- [103] Sweetnam TJ, Flack M. Ready, set, ...and difficultly slowing down: what role does alexithymia, emotional regulation and interoceptive awareness play in exercise dependence? *Acta Psychol.* 2023;237:103958. <https://doi.org/10.1016/j.actpsy.2023.103958>.
- [104] Behrmann M, Geng JJ, Shomstein S. Parietal cortex and attention. *Curr Opin Neurobiol.* 2004;14:212–7. <https://doi.org/10.1016/j.conb.2004.03.012>.
- [105] Malhotra P, Coulthard EJ, Husain M. Role of right posterior parietal cortex in maintaining attention to spatial locations over time. *Brain.* 2009;132:645–60. <https://doi.org/10.1093/brain/awn350>.
- [106] Whitlock JR. Posterior parietal cortex. *Curr Biol.* 2017;27:R691–5. <https://doi.org/10.1016/j.cub.2017.06.007>.
- [107] Miller EK, Cohen JD. An integrative theory of prefrontal cortex function. *Annu Rev Neurosci.* 2001;24:167–202. <https://doi.org/10.1146/annurev.neuro.24.1.167>.
- [108] Pitts M, Nee DE. Generalizing the control architecture of the lateral prefrontal cortex. *Neurobiol Learn Mem.* 2022;195:107688. <https://doi.org/10.1016/j.nlm.2022.107688>.
- [109] Tanji J, Hoshi E. Role of the lateral prefrontal cortex in executive Behavioral control. *Physiol Rev.* 2008;88:37–57. <https://doi.org/10.1152/physrev.00014.2007>.
- [110] Just MA, Keller TA, Malave VL, Kana RK, Varma S. Autism as a neural systems disorder: a theory of frontal-posterior underconnectivity. *Neurosci Biobehav Rev.* 2012;36:1292–313. <https://doi.org/10.1016/j.neubiorev.2012.02.007>.
- [111] Lesser IM. A review of the alexithymia concept. *Psychosom Med.* 1981;43:531–43. <https://doi.org/10.1097/00006842-198112000-00009>.
- [112] Messina A, Beadle JN, Paradiso S. Towards a classification of alexithymia: primary, secondary and organic. *J Psychopathol.* 2014;20:38–49.
- [113] Kano M, Mizuno T, Kawano Y, Aoki M, Kanazawa M, Fukudo S. Serotonin transporter gene promoter polymorphism and alexithymia. *Neuropsychobiology.* 2012;65:76–82. <https://doi.org/10.1159/000329554>.
- [114] Terock J, Weihs A, Teumer A, Klinger-König J, Janowitz D, Grabe HJ. Associations and interactions of the serotonin receptor genes 5-HT1A, 5-HT2A, and childhood trauma with alexithymia in two independent general-population samples. *Psychiatry Res.* 2021;298:113783. <https://doi.org/10.1016/j.psychres.2021.113783>.
- [115] Freyberger H. Supportive psychotherapeutic techniques in primary and secondary alexithymia. *Psychother Psychosom.* 1977;28:337–45. <https://doi.org/10.1159/000287080>.
- [116] Van Bael K, Scarfo J, Suleyman E, Katherveloo J, Grimble N, Ball M. A systematic review and meta-analysis of the relationship between subjective interoception and alexithymia: implications for construct definitions

- and measurement. *PLoS One*. 2024;19:e0310411. <https://doi.org/10.1371/journal.pone.0310411>.
- [117] Murphy J, Brewer R, Hobson H, Catmur C, Bird G. Is alexithymia characterised by impaired interoception? Further evidence, the importance of control variables, and the problems with the heartbeat counting task. *Biol Psychol*. 2018;136:189–97. <https://doi.org/10.1016/j.biopsycho.2018.05.010>.
- [118] Shah P, Hall R, Catmur C, Bird G. Alexithymia, not autism, is associated with impaired interoception. *Cortex*. 2016;81:215–20. <https://doi.org/10.1016/j.cortex.2016.03.021>.
- [119] Bilotta E, Giacomantonio M, Leone L, Mancini F, Coriale G. Being alexithymic: necessity or convenience. Negative emotionality  $\times$  avoidant coping interactions and alexithymia. *Psychol Psychother Theory Res Pract*. 2016;89:261–75. <https://doi.org/10.1111/papt.12079>.
- [120] Constantinou E, Panayiotou G, Theodorou M. Emotion processing deficits in alexithymia and response to a depth of processing intervention. *Biol Psychol*. 2014;103:212–22. <https://doi.org/10.1016/j.biopsycho.2014.09.011>.
- [121] Panayiotou G, Leonidou C, Constantinou E, Hart J, Rinehart KL, Sy JT, et al. Do alexithymic individuals avoid their feelings? Experiential avoidance mediates the association between alexithymia, psychosomatic, and depressive symptoms in a community and a clinical sample. *Compr Psychiatry*. 2015;56:206–16. <https://doi.org/10.1016/j.comppsy.2014.09.006>.
- [122] Torunsky NT, Knauz S, Vilares I, Marcoulides KM, Koutstaal W. What is the relationship between alexithymia and experiential avoidance? A latent analysis using three alexithymia questionnaires. *Personal Individ Differ*. 2023;214:112308. <https://doi.org/10.1016/j.paid.2023.112308>.
- [123] Medford N, Critchley HD. Conjoint activity of anterior insular and anterior cingulate cortex: awareness and response. *Brain Struct Funct*. 2010;214:535–49. <https://doi.org/10.1007/s00429-010-0265-x>.
- [124] Menon V. Large-scale brain networks and psychopathology: a unifying triple network model. *Trends Cogn Sci*. 2011;15:483–506. <https://doi.org/10.1016/j.tics.2011.08.003>.
- [125] Uddin LQ. Salience processing and insular cortical function and dysfunction. *Nat Rev Neurosci*. 2014;16:55–61 (2015). <https://doi.org/10.1038/nrn3857>.
- [126] Hogeveen J, Bird G, Chau A, Krueger F, Grafman J. Acquired alexithymia following damage to the anterior insula. *Neuropsychologia*. 2016;82:142–8. <https://doi.org/10.1016/j.neuropsychologia.2016.01.021>.
- [127] Gu X, Hof PR, Friston KJ, Fan J. Anterior insular cortex and emotional awareness. *J Comp Neurol*. 2013;521:3371–88. <https://doi.org/10.1002/cne.23368>.
- [128] Menon V, Uddin LQ. Saliency, switching, attention and control: a network model of insula function. *Brain Struct Funct*. 2010;214:655–67. <https://doi.org/10.1007/s00429-010-0262-0>.
- [129] Motomura Y, Fukuzaki A, Eto S, Hirabayashi N, Gondo M, Izuno S, et al. Alexithymia characteristics are associated with salience network activity in healthy participants: an arterial spin labeling study. *J Physiol Anthropol*. 2023;42:18. <https://doi.org/10.1186/s40101-023-00336-1>.
- [130] Reynolds JH, Chelazzi L. Attentional modulation of visual processing. *Annu Rev Neurosci*. 2004;27:611–47. <https://doi.org/10.1146/annurev.neuro.26.041002.131039>.
- [131] Squire RF, Zola-Morgan B, Zola-Morgan B, Moore T. Prefrontal contributions to visual selective attention. *Annu Rev Neurosci*. 2013;36:451–66. <https://doi.org/10.1146/annurev-neuro-062111-150439>.
- [132] Uddin LQ, Yeo BTT, Spreng RN. Towards a universal taxonomy of macro-scale functional human brain networks. *Brain Topogr*. 2019;32:926–42. <https://doi.org/10.1007/s10548-019-00744-6>.
- [133] Cole MW, Reynolds JR, Power JD, Repovs G, Anticevic A, Braver TS. Multi-task connectivity reveals flexible hubs for adaptive task control. *Nat Neurosci*. 2013;16:1348–55. <https://doi.org/10.1038/nn.3470>.
- [134] Wen T, Liu D-C, Hsieh S. Connectivity patterns in cognitive control networks predict naturalistic multitasking ability. *Neuropsychologia*. 2018;114:195–202. <https://doi.org/10.1016/j.neuropsychologia.2018.05.002>.
- [135] Boonstra JT. The cerebellar connectome. *Behav Brain Res*. 2025;482:115457. <https://doi.org/10.1016/j.bbr.2025.115457>.
- [136] Mannarelli D, Pauletti C, Missori P, Trompetto C, Cotellessa F, Fattaposta F, et al. Cerebellum's contribution to attention, executive functions and timing: psychophysiological evidence from event-related potentials. *Brain Sci*. 2023;13:1683. <https://doi.org/10.3390/brainsci13121683>.
- [137] Zhang P, Duan L, Ou Y, Ling Q, Cao L, Qian H, et al. The cerebellum and cognitive neural networks. *Front Hum Neurosci*. 2023;17:1197459. <https://doi.org/10.3389/fnhum.2023.1197459>.
- [138] Luminet O, Nielson KA, Ridout N. Cognitive-emotional processing in alexithymia: an integrative review. *Cogn Emot*. 2021;35:449–87. <https://doi.org/10.1080/02699931.2021.1908231>.
- [139] van Buuren M, Gladwin TE, Zandbelt BB, Kahn RS, Vink M. Reduced functional coupling in the default-mode network during self-referential processing. *Hum Brain Mapp*. 2010;31:1117–27. <https://doi.org/10.1002/hbm.20920>.
- [140] Davey CG, Pujol J, Harrison BJ. Mapping the self in the brain's default mode network. *NeuroImage*. 2016;132:390–7. <https://doi.org/10.1016/j.neuroimage.2016.02.022>.
- [141] Parker JDA, Taylor GJ, Bagby RM. The 20-item Toronto alexithymia scale. III. Reliability and factorial validity in a community population. *J Psychosom Res*. 2003;55:269–75. [https://doi.org/10.1016/s0022-3999\(02\)00578-0](https://doi.org/10.1016/s0022-3999(02)00578-0).
- [142] Gotgay N, Giedd JN, Lusk L, Hayashi KM, Greenstein D, Vaituzis AC, et al. Dynamic mapping of human cortical development during childhood through early adulthood. *Proc Natl Acad Sci*. 2004;101:8174–9. <https://doi.org/10.1073/pnas.0402680101>.
- [143] Fair DA, Cohen AL, Dosenbach NUF, Church JA, Miezin FM, Barch DM, et al. The maturing architecture of the brain's default network. *Proc Natl Acad Sci*. 2008;105:4028–32. <https://doi.org/10.1073/pnas.0800376105>.
- [144] Yoshikawa A, Masaoka Y, Yoshida M, Koiwa N, Honma M, Watanabe K, et al. Heart rate and respiration affect the functional connectivity of default mode network in resting-state functional magnetic resonance imaging. *Front Neurosci*. 2020;14:631. <https://doi.org/10.3389/fnins.2020.00631>.
- [145] Berthoz S, Consoli S, Perez-Diaz F, Jouvent R. Alexithymia and anxiety: compounded relationships? A psychometric study. *Eur Psychiatry*. 1999;14:372–8. [https://doi.org/10.1016/S0924-9338\(99\)00233-3](https://doi.org/10.1016/S0924-9338(99)00233-3).
- [146] Preece DA, Petrova K, Mehta A, Sikka P, Gross JJ. Alexithymia or general psychological distress? Discriminant validity of the Toronto alexithymia scale and the Perth alexithymia questionnaire. *J Affect Disord*. 2024;352:140–5. <https://doi.org/10.1016/j.jad.2024.01.271>.
- [147] Lumley MA. Alexithymia and negative emotional conditions. *J Psychosom Res*. 2000;49:51–4. [https://doi.org/10.1016/S0022-3999\(00\)00161-6](https://doi.org/10.1016/S0022-3999(00)00161-6).
- [148] Moormann PP, Bermond B, Vorst HCM, Bloemendaal AFT, Teijn SM, Rood L. New avenues in alexithymia research: the creation of alexithymia types. In: Vingerhoets AJJM, Nyklíček I, Denollet J, editors. *Emot. Regul*. Boston, MA: Springer US; 2008, pp. 27–42. [https://doi.org/10.1007/978-0-387-29986-0\\_3](https://doi.org/10.1007/978-0-387-29986-0_3).
- [149] Preece DA, Becerra R, Boyes ME, Northcott C, McGillivray L, Hasking PA. Do self-report measures of alexithymia measure alexithymia or general psychological distress? A factor analytic examination across five samples. *Personal Individ Differ*. 2020;155:109721. <https://doi.org/10.1016/j.paid.2019.109721>.
- [150] Xavier M, Esteves I, Jorge J, Abreu R, Giraud A-L, Sadaghiani S, et al. Consistency of resting-state correlations between fMRI networks and EEG band power. *Imaging Neurosci Camb Mass*. 2025;3:IMAG.a.37. <https://doi.org/10.1162/IMAG.a.37>.
- [151] Moreno-Ayure M, Páez C, López-Arias MA, Mendez-Betancurt JL, Ordóñez-Rubiano EG, Rudas J, et al. Establishing an acquisition and processing protocol for resting state networks with a 1.5 T scanner: a case series in a middle-income country. *Medicine (Baltimore)*. 2020;99:e21125. <https://doi.org/10.1097/MD.00000000000021125>.
- [152] Krasnow B, Tamm L, Greicius MD, Yang TT, Glover GH, Reiss AL, et al. Comparison of fMRI activation at 3 and 1.5 T during perceptual, cognitive, and affective processing. *NeuroImage*. 2003;18:813–26. [https://doi.org/10.1016/S1053-8119\(03\)00002-8](https://doi.org/10.1016/S1053-8119(03)00002-8).
- [153] The SINAPOSE Collaborative Group, Wardlaw JM, Brindle W, Casado AM, Shuler K, Henderson M, et al. A systematic review of the utility of 1.5 versus 3 tesla magnetic resonance brain imaging in clinical practice and research. *Eur Radiol*. 2012;22:2295–303. <https://doi.org/10.1007/s00330-012-2500-8>.
- [154] Voss HU, Zevin JD, McCandliss BD. Functional MR imaging at 3.0 T versus 1.5 T: a practical review. *Neuroimaging Clin N Am*. 2006;16:285–97. <https://doi.org/10.1016/j.nic.2006.02.008>.